

eco plant

Implant System

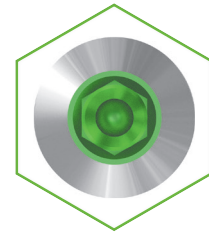
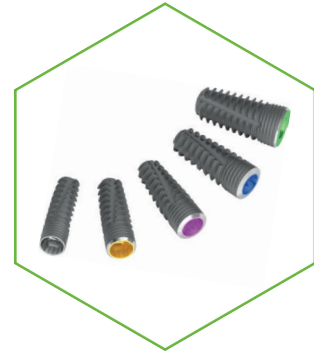

Table of contents



Introduction

About the company	3
Technology and quality	4
Implant surface finish	6
Applied raw materials	7
Packaging	8



ECO-PLANT Implant System

Distinctive characteristics of the Eco-plant Implant System	14
The applicational fields of Eco-plant	16
Ø 3.5 implant diameter	19
Ø 4.0 implant diameter	19
Ø 4.5 implant diameter	19
Ø 5.0 implant diameter	19
Ø 6.0 implant diameter	19

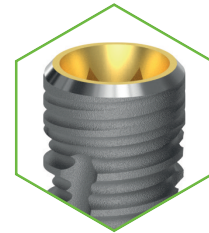

ECO-PLANT abutment system

Eco-plant abutments	24
Sizes available of the Eco-plant abutments	34
Sizes available of the Eco-plant screws	46

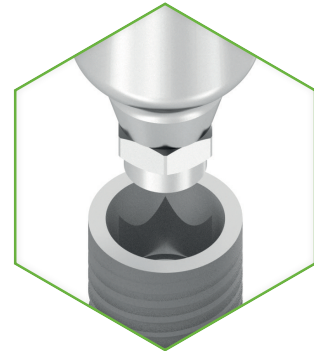

Instruments

Eco-plant Surgical Instruments	50
Surgical drills	54
Ratchet torque wrench	55





About the company

Bionika Medline Kft. was established in 1989 by private individuals as a family-owned Hungarian company.

We have more than 35-year-experience in the field of medical instruments and implant development, production and trade. BIONIKA as a researcher, developer, manufacturer and distributor is present in dentistry, oral surgery, traumatology, orthopedics and rehabilitation in the medical-professional areas.

According to our objective and perception, we attach great importance to the word „BIONIKA“, which marks a scientific thinking on the boundaries of biology, technology and electronics that combines these three areas in our researching and developing work.

Clinical and technological experiences: The continuous process, combination and utilization of clinical and technological experiences in development contributes to our success, up to the production base. Here you will find the best solutions and constructions suited to customer needs, which are under continuous development.

Development: The owners of BIONIKA put great emphasis on continuous product and technological research and development. Our products are developed in close collaboration with doctors and engineers, enabling us to ensure the world-class quality and practical utilization.

Quality: The quality of the products expected by our customers is guaranteed by design, manufacturing and quality management according to the harmonized European Union laws. The BIONIKA Medline Kft. is operated according to the EN ISO 9001 and the EN ISO 13485 quality management system. Our products are provided with CE marks.

Guarantee: After inserting the implant - the risk of the ossification process is assumed by BIONIKA, independently of cause and effect relationship – exchange guarantee is ensured within one year after the purchase. Otherwise, we provide a long-term, 10-year guarantee for our products.



DENTISTRY

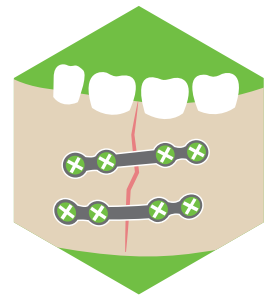

ORAL SURGERY



TRAUMATOLOGY



ORTHOPEDICS

Technology

BIONIKA Medline Kft. has 35 years of experience in the development and production of dental implants, dental insertion instruments and stomatological parts. During this time more than 40 types of implant systems have been developed and are being manufactured to date, including insertion instruments. Some of these parts have been developed for their own marketing in accordance with their own market needs.

Other systems – in cooperation with independent medical groups – are made to order, mainly developed and manufactured for foreign markets. (These are sold by the customers under their own brand name).

Our partners can choose from approximately 20.000 different parts of different sizes and shapes. Our manufacturing technology is flexible, we can quickly move from one component to another, and we are able to fulfill thousands of orders with a short turnaround time. This area requires high precision production (in some cases it is necessary to hold 2-5 mm tolerances).

All the technological operations we carry out are from manufacturing, surface design, packaging. Our products are CE marked and the production process is under strict quality management system. Biocompatible materials are the most important raw materials for dental, oral surgery, traumatology and orthopedic medical implants. Because relatively small series of customized solutions are required, they require fast programmable CNC machining technology.

Accordingly, we have molded CNC machining centers and Swiss type longitudinal machining centers. For machining more complex surfaces, an industrial 5-axis CNC center is used with CAD-CAM system support. Our machines are equipped not only with fixed, but also with propelled cutting instrument units, with which we can perform more complex spatial geometrical machining. As a complementary technology, we have sandblasting, polishing titanium coloring and sterilization equipments. The production of custom prosthetic components for dental applications is supported by the BIONIKA Milling center.

Our Partners

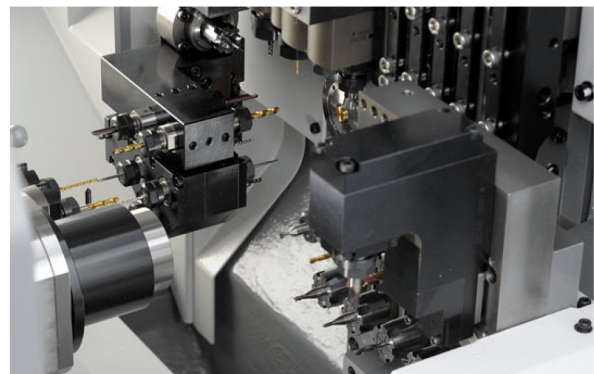

Quality management and guarantee

The quality of the products is guaranteed by design, manufacturing and quality management according to the harmonized European Union laws. The BIONIKA Medline Kft. is operated according to the EN ISO 9001 and the EN ISO 13485 quality management system. Our products are provided with CE marks, which was ensured by EMKI and QT-CERT.

We provide a long-term, 10-year guarantee for our products. After inserting the implant, reducing the medical risk of the ossification process, independently of cause and effect relationship – exchange guarantee is ensured within one year after the purchase for the dropped and fallen out implants.



BIONIKA Medline Ltd. has always paid special attention to quality and reliability during its more than 35 years of existence. The Dun&Bradstreet certificate testifies to the reliability and stability of our company. BIONIKA has been awarded the „Triple A” D&B certification every year between 2016 and 2025.

Only 0.63 % of companies in Hungary have an AAA (triple A) rating, with whom the financial risk of establishing a business relationship is extremely low - source: dnb.hu

Superclean implant surface

BIONIKA demonstrates the best qualities of Grade 4 titanium used in implant manufacturing for dental implantology according to the ISO 5832-2 ASTM F67 standard. Due to its adequate purity the biocompatibility is exceptionally good as well as it is provided with exceptional solidity.

Initially, we and other implant manufacturers preferred the higher purity titanium but due to solidity reasons nowadays almost every implant is made of Grade 4 or other alloyed titanium in the world.

In all cases of implant abutments, alloyed, high strength Grade 5 titanium is applied according to the ISO 5832-3 ASTM F136 standard. The titanium applied according to the standard is provided with exceptional biocompatibility, it is almost risk-free.

Almost all professionals see that the implantation success is best determined by the implantologist's practice, as well as surgical conditions, carefully maintained hygiene, and patient abilities.

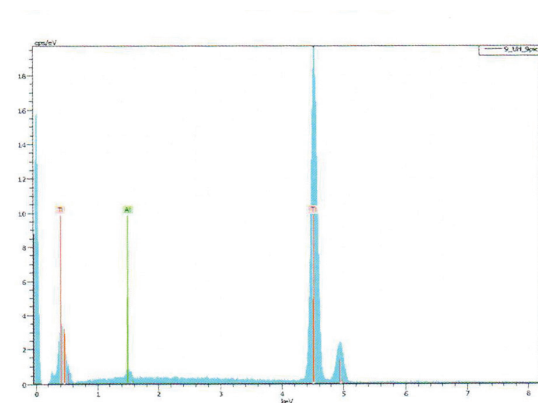

Energy dispersive X-ray spectrometric elemental analysis of Bionika implants*

The main steps of our BioTiS surface finish technology:

- Chemical, mechanical surface cleaning and surface dewing
- Special ultrasonic cleaning, surface cleaning and sterilization
- Transformation of surface structure by acidification process
- Multi-stage dehumidification, cleaning
- Electrochemical surface modification
- Sterilization
- Surface finish in physiological solution

These technological steps are always carried out under sterile conditions.

The final packaging of the implants is four-layered. The packaging is carried out in a sterile cabin. Final sterility is assured by an accredited 20 Rad gamma sterilization procedure.

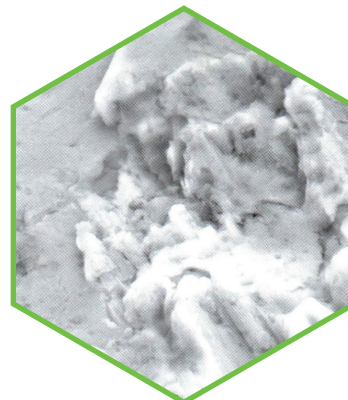
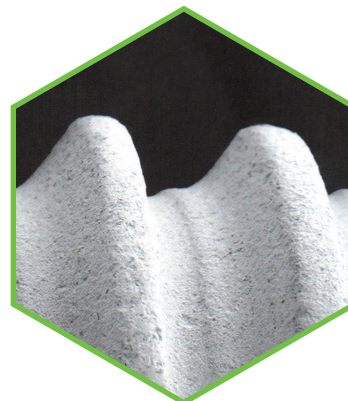

*Source: FOGSurgical SZEMLE, year 106. No. 4.. 2013. 135-143

Bionika implant electron microscope i*

Applied raw materials

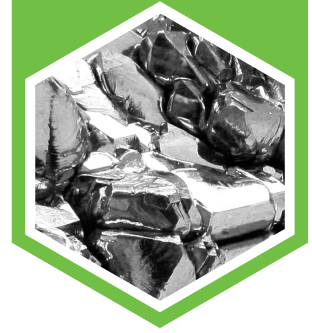

Titanium grade 4

Chemical composition

Elements	Threshold limit of constituents(%)
O	0,4 max.
Fe	0,3 max.
C	0,1 max.
N	0,05 max.
H	0,0125 max.
Ti	>99% / balance

Mechanical properties

solidity	680 MPa min.
dilation	10 %

According to the **ISO 5832-2** standard.

Titanium Grade 5

Chemical composition

Elements	Threshold limit of constituents(%)
Al	5,5-6,75 max.
V	3,5-4,5 max.
Fe	0,3 max.
O	0,2 max.
C	0,08 max.
N	0,05 max.
H	0,015 max.
Ti	balance

Mechanical properties

solidity	860 MPa min.
dilation	10 %

According to the **ISO 5832-3** standard.

CoCr

Chemical composition

Elements	Threshold limit of constituents(%)
C	0,1 max.
Si	1,0 max.
Mn	1,0 max.
P	0,005 max.
S	0,005 max.
Cr	30, 0 max.
Mo	7,0 max.
Ni	1,0 max.
Co	-
N	0,2250 max.

Mechanical properties

solidity	1240,00 MPa min.
elongation limit	900,00 min.
elongation at break	18,00 min.
fracture contraction	23,00 min.

According to the **ISO 5832-12** standard.

Plastics

POM (polyoxymethylene) : Thermoplastic synthetic plastic, Excellent properties eg: high hardness, low wear, good flexibility, little absorbing ability. Density: 1.41 g / cm³. elongation at break: min. 30% Current Voltage: min. 65 Mpa. Its color is white.

PEEK (polyether ether ketone) :High heat-resistant plastic, suitable for all conventional sterilization methods (steam, dry heat, ethylene oxide, gamma radiation). Density: 1.30 1.41 g / cm³ Tensile strength: 115 Mpa. elongation at break: min. 17% Its colour is natural brownish gray.

eco-plant packaging



10-piece collection box



vial in sterile foil



removing the foil



sterile vial



removing the locking plug (1)



removing the locking plug (2)

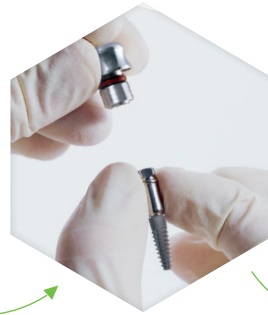

the implant and the multifunctional head in the locking plug



using the implant key driver

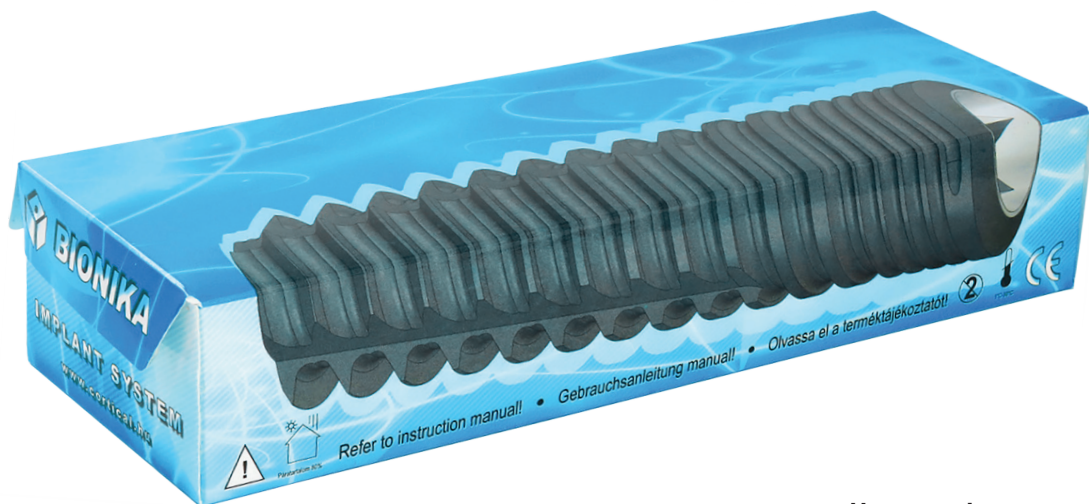

Collection box

Depending on the order quantities, collection boxes with 5 and 10 pieces are applied.

eco-plant packaging



According to our endeavor, the raw materials used in packaging are almost 100% naturally occurring, environmentally-friendly, natural materials.

aluminum · titanium · glass · caoutchouc · paper

Vial

The first layer of the packaging is a transparent vial, which ensures the total, null colony-forming unit sterility. The locking plug of the vial holds the implant, the multifunctional implant head and the locking screw.



Eco, Normál Implantátum	
Ø 4,00 x L11,00 mm	
REF 501.001.380.110	2016-06
LOT 160517-15	2021-06
CE 1008	STERILE R
CM 007	
BIONIKA Medline Kft. www.bionika.hu	

Paper box

The outer layer of the packaging is a paper box with a high density, which is for the physical safety. Every paper box is provided with colour-coded labels according to the different platform- diameters. The colour of the packaging is adjusted to this method.



The sectional image of the **eco-plant** packaging and its accessories



The first layer of the packaging is a transparent vial. The implant and the multifunctional head are held by the vial locking plug and with this they can be removed from the vial. The implant locking screw can be found in the vial locking plug as well.

The **multifunctional head** doesn't only hold the implant in the packaging but also helps its inserting into the jaw bone, is suitable for closed spoon sampling and after this it can be drilled as a head for the glued toothwork.

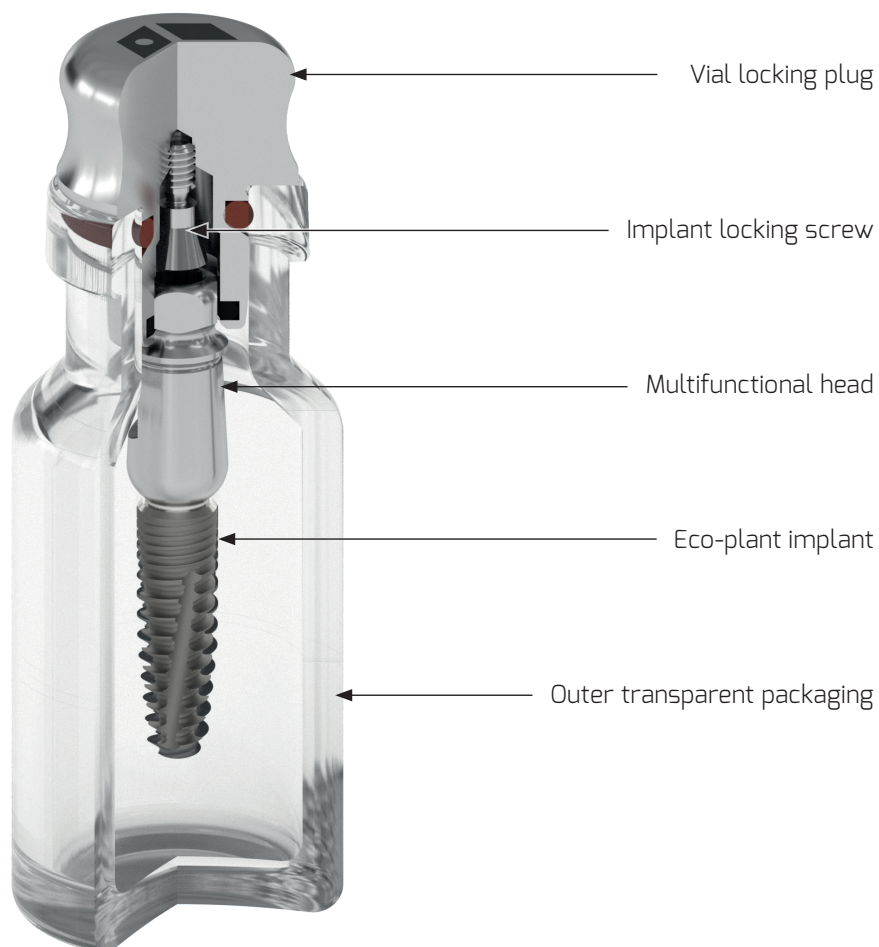

eco-plant product labels and their notation

Differential platform diameters by colour:

- 3,5 mm - grey
- 4,0 mm - yellow
- 4,5 mm - purple
- 5,0 mm - blue
- 6,0 mm - green

Information supplied by the three product labels to the outer packaging of the Implant System:

The side of the box:

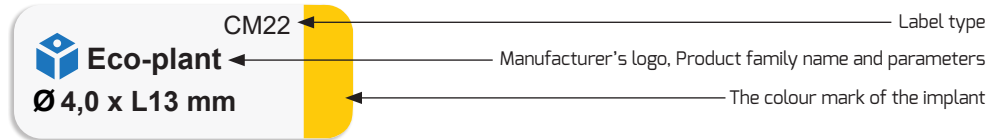

Top of the box:

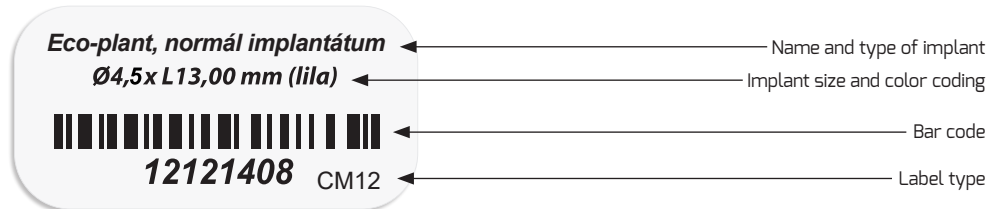

The back of the box:

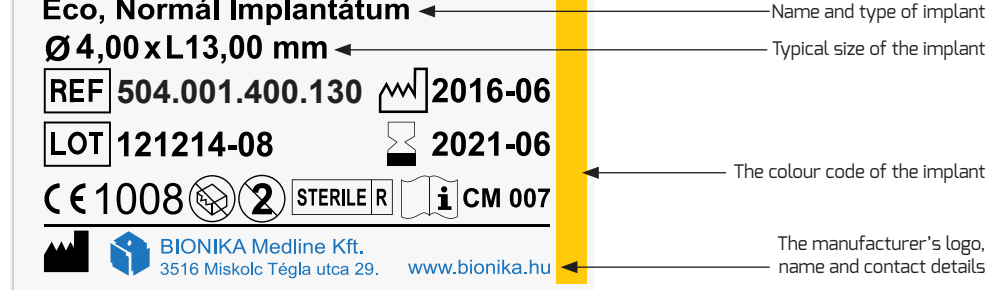

Explanation of label codes:

<p> Diameter</p> <p> Implant length</p> <p> Item number</p> <p> Serial number</p> <p> Production time</p>	<p> Expiration date</p> <p> It is forbidden to use in the case of damaged packaging.</p> <p> Reuse is forbidden!</p> <p> Sterilized with gamma rays</p> <p> sterilized with steam or dry heat</p>	<p> Non-sterile product in the package</p> <p> Read the usage guide!</p> <p> Certification company code</p> <p> Manufacturer's name and Contact</p>
---	---	---

eco
plant
IMPLANT SYSTEM



IMPLANT SYSTEM | TABLE OF CONTENTS

Distinctive characteristics of the Eco-plant implant system..14
The applicational fields of Eco-plant 16
Sizes available of the implants 18
Drilling protocol 20



Distinctive characteristics of the **eco-plant** implant system

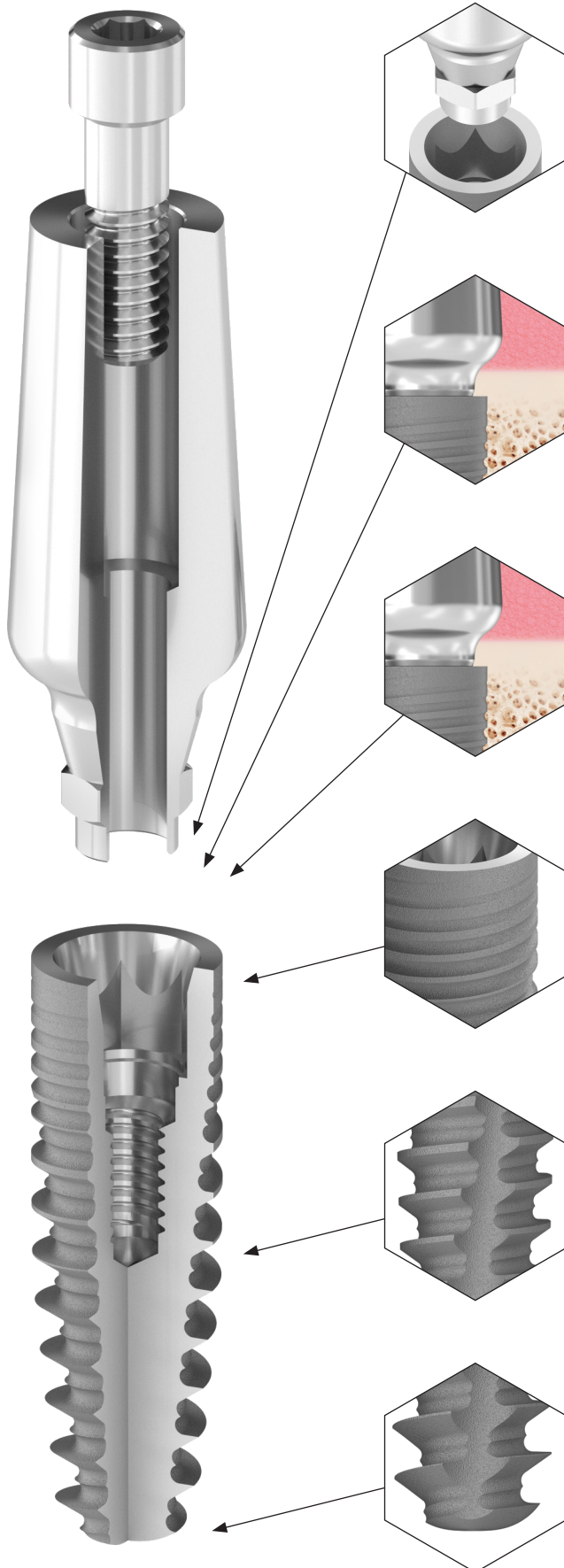

Connection: Cone and hex and cylinder

The most perfect fixation is provided which is well-proven in the engineering practice. 30 degree cone angle is applied which eventuates micromotor-free power transmission and offers favorable conditions for the accurate open or closed spooned sampling. It superimposes the powers deep right into the implant.

Cortical Level

The chances of the implant persistency are significantly improved by inserting the upper edge of the implant at the cortical level or below (from 0,5 to 1 mm) which is proven by surgical experiences on the long run.

Platform switching

The diameter of the abutment is smaller than the outer part of the implant which is connected to the bone. This way the soft tissue closes upon the ingoing aperture and the implant's connecting surface of the bone nest, covering, insulating that like as a sealing ring.

Spirally microstriated cortical surface

The multi-paragraphed microstriated spiral surface can function as a significant weight bearing element connected to the cortical and ensuring micromotor-free condition for the fast inserting. This self-closing thread structure due to the cycloid cord thread geometry helps facilitating dynamic force convection and ensures micromotor-free condition for fast insertion.

Anatomical root form

The Eco-plant follows the form of the anatomical tooth root. Due to the conicity, high thread pitch, high thread deepness, self-closing and self-tapping shaping of the implant screw thread, it has a bone-compacting effect. Thus, there is an option for immediate loadness of the implant as needed as a result of the high primer stability.

Rounded implant end

It helps facilitating the minor direction changes when inserting the implant.

The functional structure of the **eco-plant** system elements

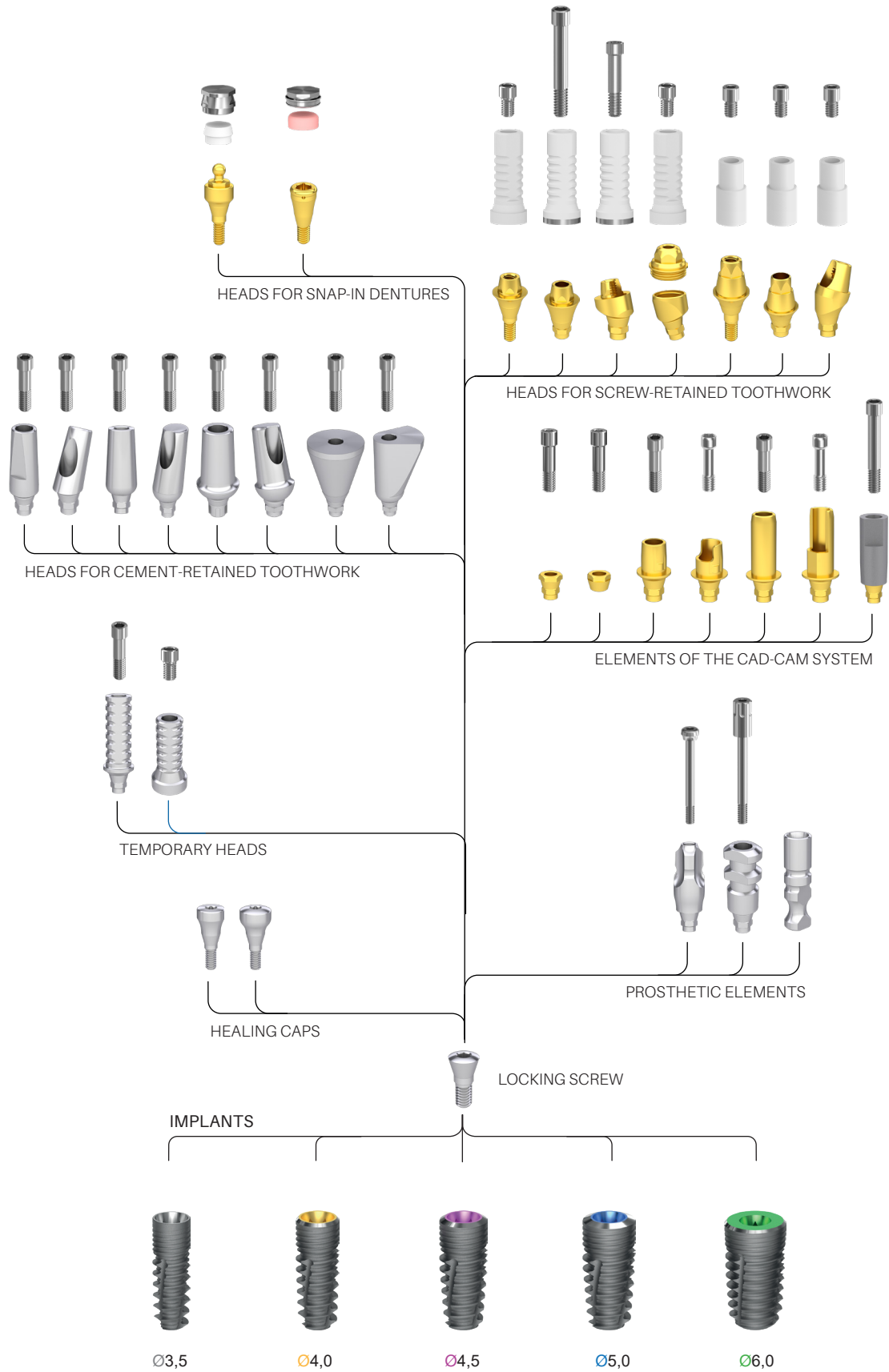

The applicational fields of the **eco-plant** implant system



In the case of one tooth deficiency

In this case of the replacement of a tooth, we do not have to grind two healthy teeth for bridge replacement, but inserting an implant, then we need to glue a crown in the same way as the traditional one.

In the case of end of line tooth deficit(s)

In this case, in the absence of a pillar tooth, we are not able to make a fixed replacement (bridge). With the implantation of at least two implants, you are already make the (fixed) bridge replacement.

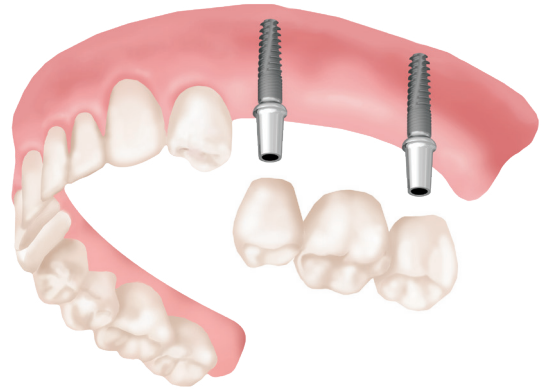

Removeable denture

In the case of total tooth deficit

In this case the patient has no tooth, complete tooth augmentation can be performed. In this case, there one solution is the removable denture: 2-4 implants are implanted, these will be the fixation for the removable tooth.

This brings a tremendous quality of life to the patient, as this way the denture will be very stable, so it can be used in chewing and speaking outright. There are two solutions possible in this case: ball head or locator head abutments can be applied.

With the implantation of several 6-8 implants, it is possible to make full fixation (round bridge) augmentation, which is both functional and aesthetically close to the natural teeth.

Screw-retained fixed dental prosthetics

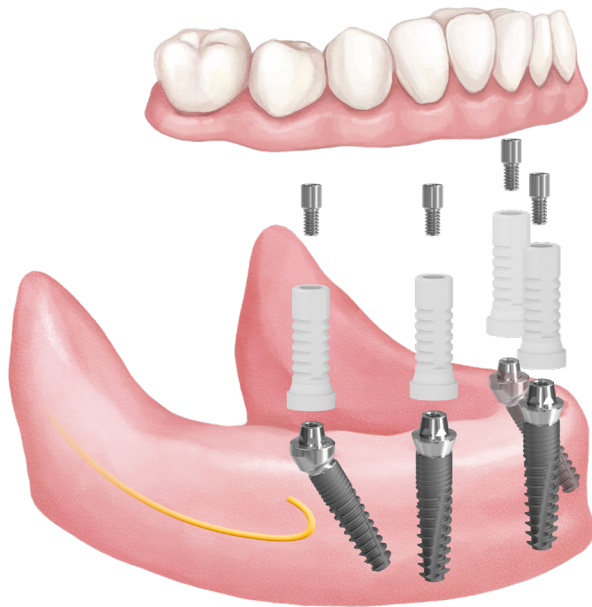

Optimum Concept

Optimum Concept

All-on-4® type - Economical Solution

The Optimum Concept provides great stability, with only four implants being implanted.

- The temporary denture can be inserted on the day of surgery.
- Immediate improvement in function, speech and aesthetically.
- Treatment times are shorter and costs can be lower than conventional implant placement modes.
- Tilt rear implants can be fixed better into the front bone. This promotes prosthesis support.

Safe Concept

All-on-6® type - For extra stability

The stability of the toothwork can be increased with the Safe Concept. It is exceptionally advantageous in the case of extra chewing ability.

- The usage of oblique head implants allows longer implants to be used, avoiding the nerve canal.
- The usage of longer implants allows the bone and the implant to touch on a larger surface, thus making bone augmentation avoidable.
- Favorable bone level for tilted and axial implants.
- High remaining chances.

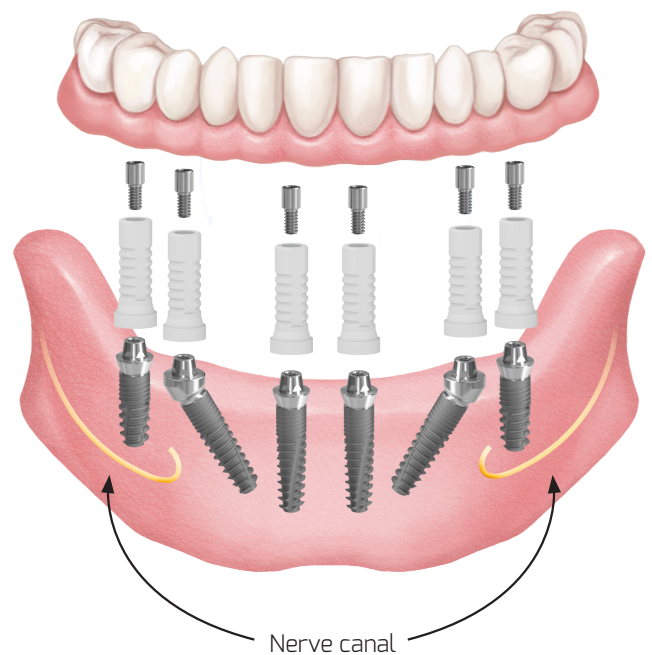

Safe Concept

eco-plant implant system

Sizes available of the Eco-plant implants

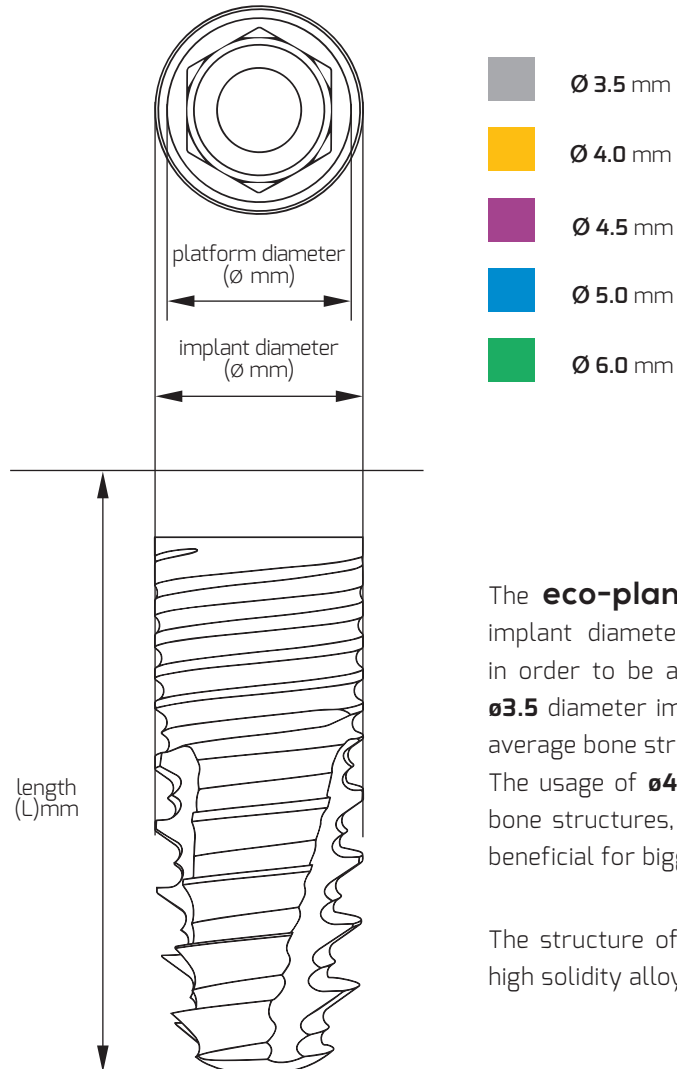



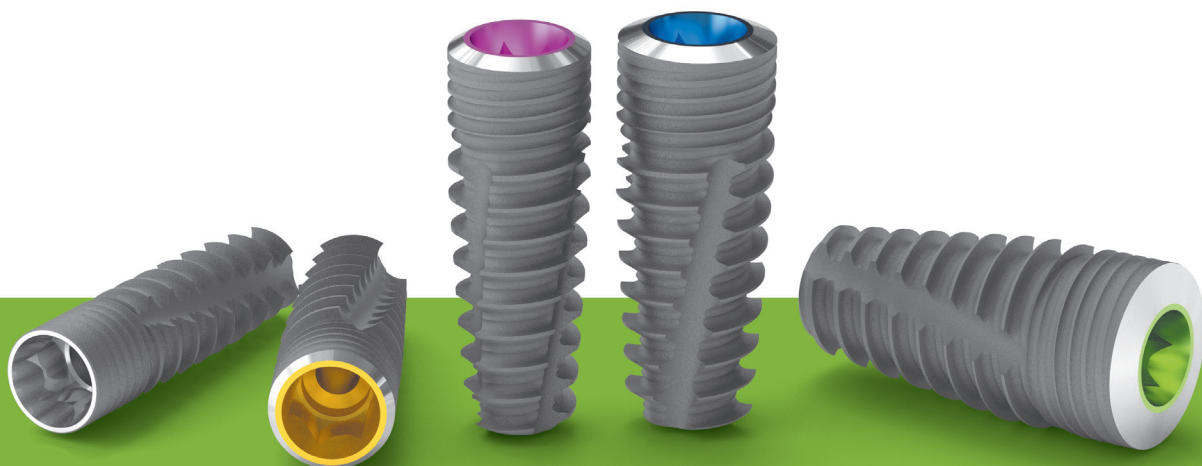

The **eco-plant** implant system consists of five different implant diameters. Every implant diameter has five lengths in order to be an adequate solution for every situations. The **Ø3.5** diameter implant is exceptionally suitable for thinner than average bone structures for holding toothworks on the long run. The usage of **Ø4.0** and **Ø4.5** diameter is beneficial for average bone structures, and the **Ø5.0** and **Ø6.0** diameter implants are beneficial for bigger than average bone stocks.

The structure of every Eco implant is homogeneous, made of high solidity alloyed titanium.







Ø 3.5

inserting length (L):

				
7 mm	9 mm	11 mm	13 mm	15 mm

Ø 4.0

inserting length (L):

				
7 mm	9 mm	11 mm	13 mm	15 mm

Ø 4.5

inserting length (L):

				
7 mm	9 mm	11 mm	13 mm	15 mm





Ø 5.0

inserting length (L):

				
7 mm	9 mm	11 mm	13 mm	15 mm

Ø 6.0

inserting length (L):

				
7 mm	9 mm	11 mm	13 mm	15 mm

The drilling protocol of the **eco-plant** implant system

Drilling Indicators:



- alternatively used



- 1/2 length drilling alternatively



- recommended drilling in 3/4 or in full length

Ø 3.5 mm implant drilling protocol

implant diameter

Ø 3.5

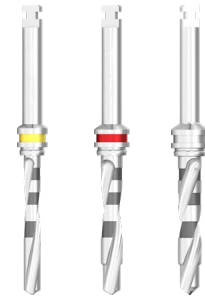

colour-coded drill diameter

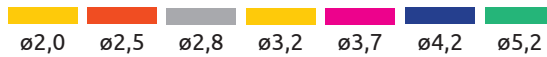

Ø 4.0 mm implant drilling protocol

implant diameter

Ø 4.0

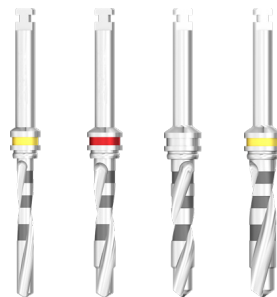

colour-coded drill diameter

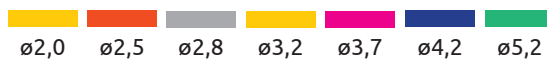

Ø 4.5 mm

implant drilling protocol

implant diameter

Ø 4.5

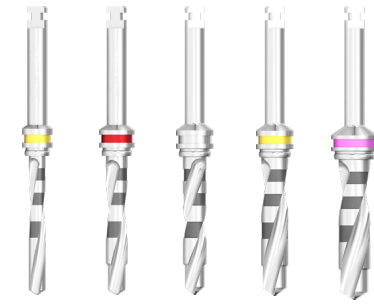

colour-coded drill diameter



Ø 5.0 mm

implant drilling protocol

implant diameter

Ø 5.0

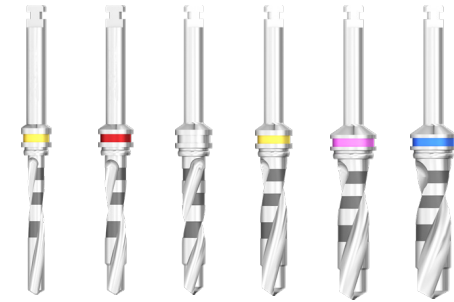

colour-coded drill diameter

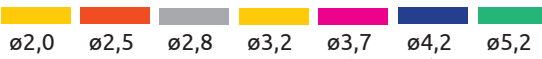

Ø 6.0 mm

implant drilling protocol

implant diameter

Ø 6.0

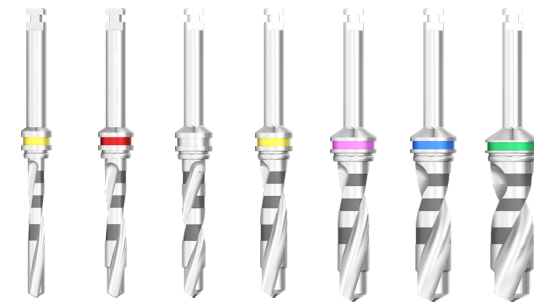

colour-coded drill diameter





eco
plant
ABUTMENT SYSTEM

ABUTMENT SYSTEM | TABLE OF CONTENTS

Abutments	24
Sizes available of abutments	34
Sizes available of screws.....	46



eco-plant abutments

1. IMPLANTS

PROSTHETIC ELEMENTS

2. Lab analog
3. Lab analog, for digital scan
4. Lab analog, locator
5. Lab analog, ball attachment
6. Lab analog, multi-unit
7. Lab analog, multi-unit SR
8. Lab analog, multi-unit digital
9. Lab analog, multi-unit digital SR
10. Healing abutment, narrow
11. Healing abutment, anatomical
12. Healing abutment, anatomical, local
13. Healing abutment, conical



110.



130.



130.



130.



1.



2.



3.



4.



5.



6.



7.



8.



9.



10.



11.



12.



13.

- 14. Healing abutment, multi-unit
- 15. Healing abutment, multi-unit SR
- 16. Healing abutment, multi-unit, local
- 17. Impression coping for open tray
- 18. Impression coping for open tray, multi-unit level, positioned
- 19. Impression coping for open tray, multi-unit level, non-positioned
- 20. Impression coping for open tray, multi-unit level, positioned, SR
- 21. Impression coping for open tray, multi-unit level, non-positioned, SR
- 22. Impression coping for closed tray
- 23. Impression coping for closed tray, multi-unit level, positioned
- 24. Impression coping for closed tray, multi-unit level, non-positioned
- 25. Impression coping for closed tray, multi-unit level, positioned, SR
- 26. Impression coping for closed tray, multi-unit level, non-positioned, SR

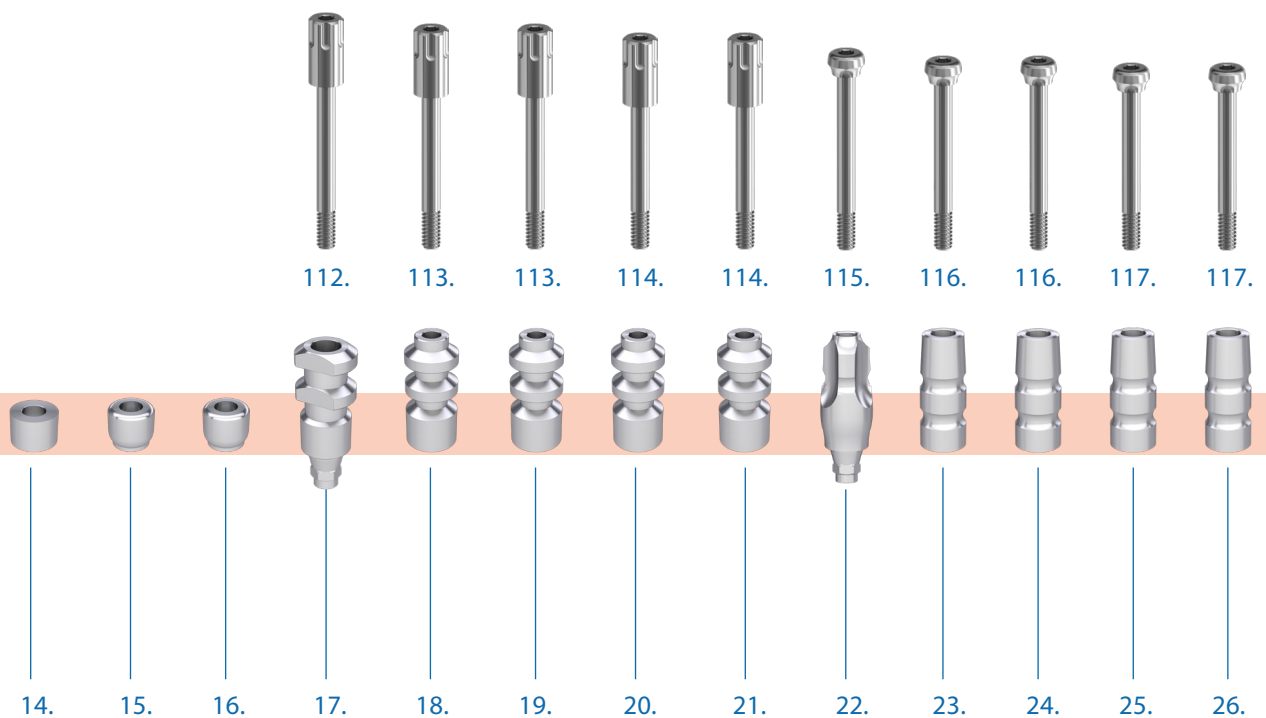

eco-plant abutments

- 27. Impression coping for closed tray, parallel
- 28. Impression coping for closed tray, angled
- 29. Temporary abutment, implant level, positioned
- 30. Temporary abutment, multi-unit level, positioned
- 31. Temporary abutment, multi-unit level, non-positioned
- 32. Temporary abutment, multi-unit level, positioned, SR

- 33. Temporary abutment, multi-unit level, non-positioned SR

FOR CEMENT-RETAINED RESTORATIONS

- 34. Narrow abutment, straight
- 35. Narrow abutment, angled
- 36. Universal abutment, straight, positioned
- 37. Universal abutment, straight, non-positioned

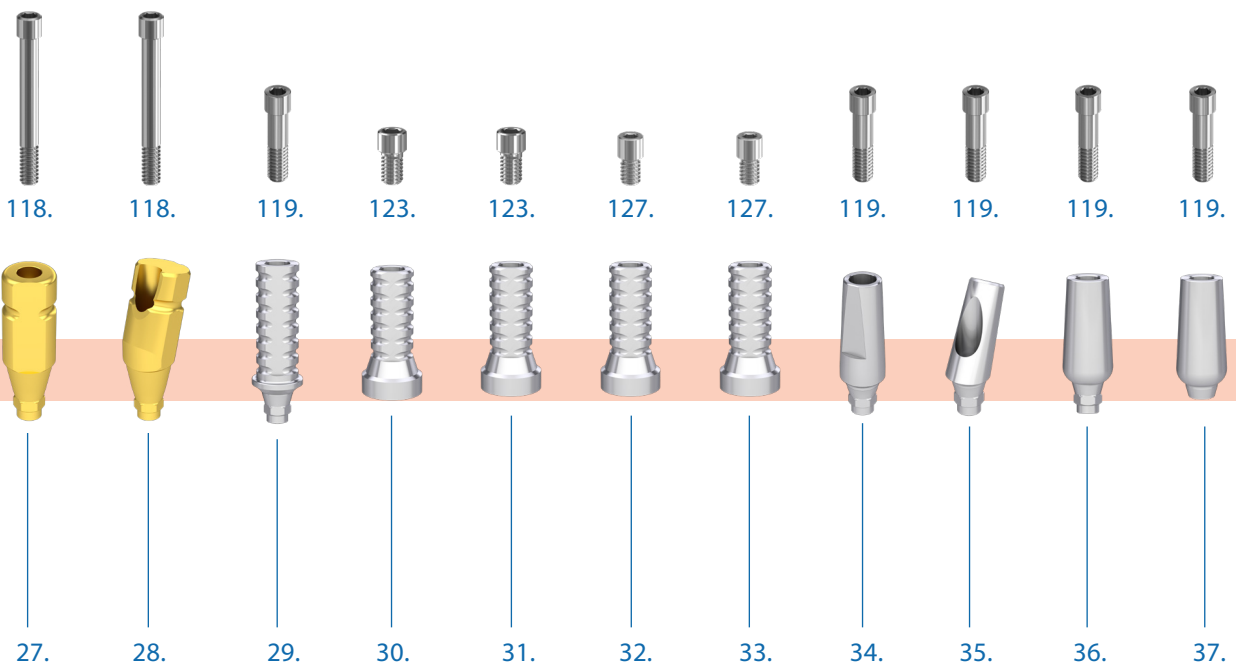

- 38. Universal abutment, straight MV
- 39. Universal abutment, angled
- 40. Anatomical abutment, straight
- 41. Anatomical abutment, angled
- 42. Cylindrical abutment
- 43. Trapezoidal abutment
- 44. Delta abutment

CASTING ABUTMENTS

- 45. BR interface
- 46. BR interface, screwable
- 47. Castable plastic abutment, for BR interface, positioned
- 48. Castable plastic abutment, for BR interface, non-positioned

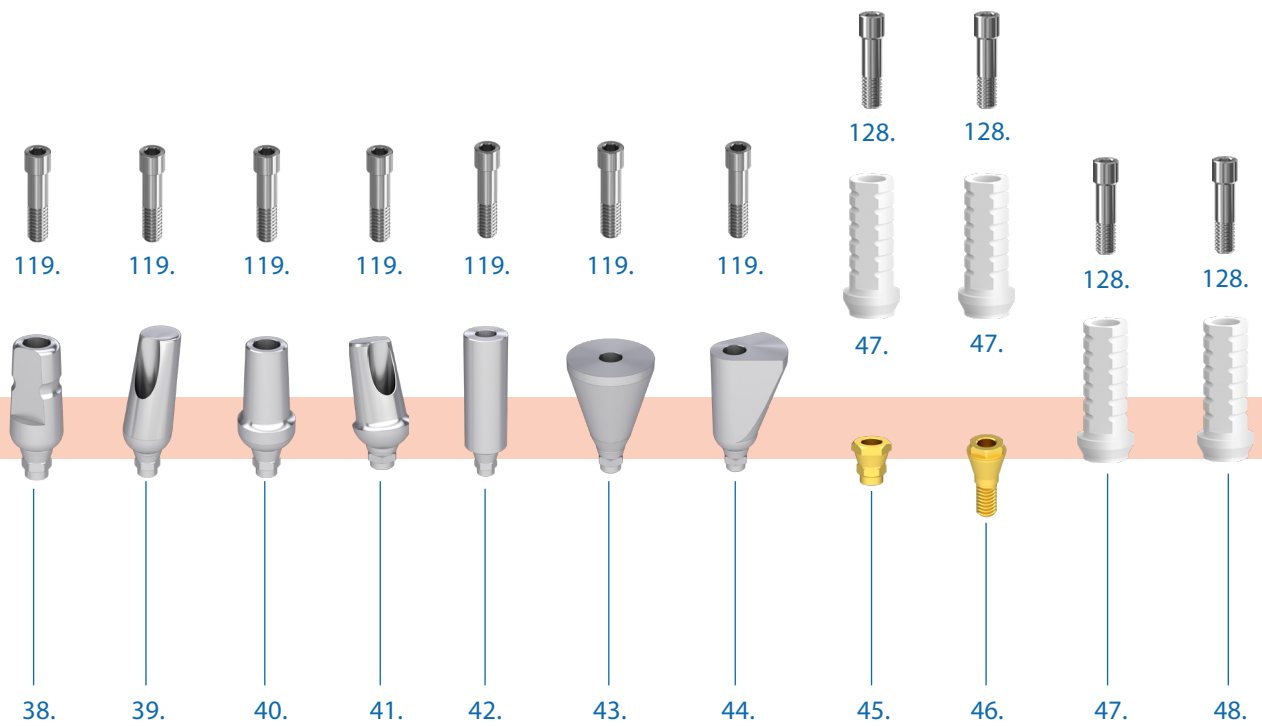

eco-plant abutments

- 49. Castable plastic abutment, for titanium base
- 50. Castable plastic abutment, for multi-unit level titanium base
- 51. Castable plastic abutment, angled, for multi-unit level titanium base
- 52. Castable plastic abutment, for multi-unit level titanium base, SR
- 53. Castable plastic abutment, angled, for multi-unit level titanium base, SR
- 54. Castable plastic abutment, multi-unit level, positioned
- 55. Castable plastic abutment, multi-unit level, non-positioned
- 56. Castable plastic abutment, angled, multi-unit level
- 57. Castable plastic abutment, multi-unit level, positioned, SR
- 58. Castable plastic abutment, multi-unit level, non-positioned, SR
- 59. Castable plastic abutment, angled, multi-unit level SR

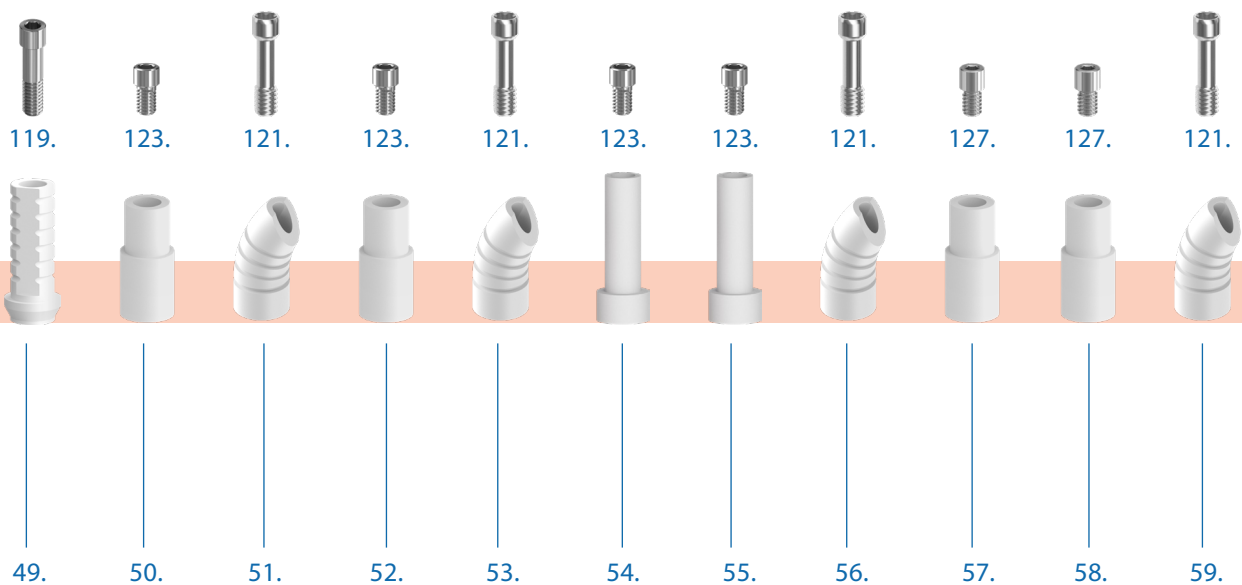

FOR SNAP IN DENTURES

- 60. Ball attachment abutment OC
- 61. Ball attachment abutment, angled OC
- 62. Locator abutment
- 63. Locator abutment, mini
- 64. Locator abutment, multi-unit level
- 65. Locator abutment, multi-unit level SR
- 66. Locator abutment, mini, multi-unit level

- 67. Locator abutment, angled
- 68. OC cap, metal
- 69. OC insert, plastic
- 70. O-ring
- 71. O-ring's metal cap
- 72. Locator cap set
- 73. Microlock cap set

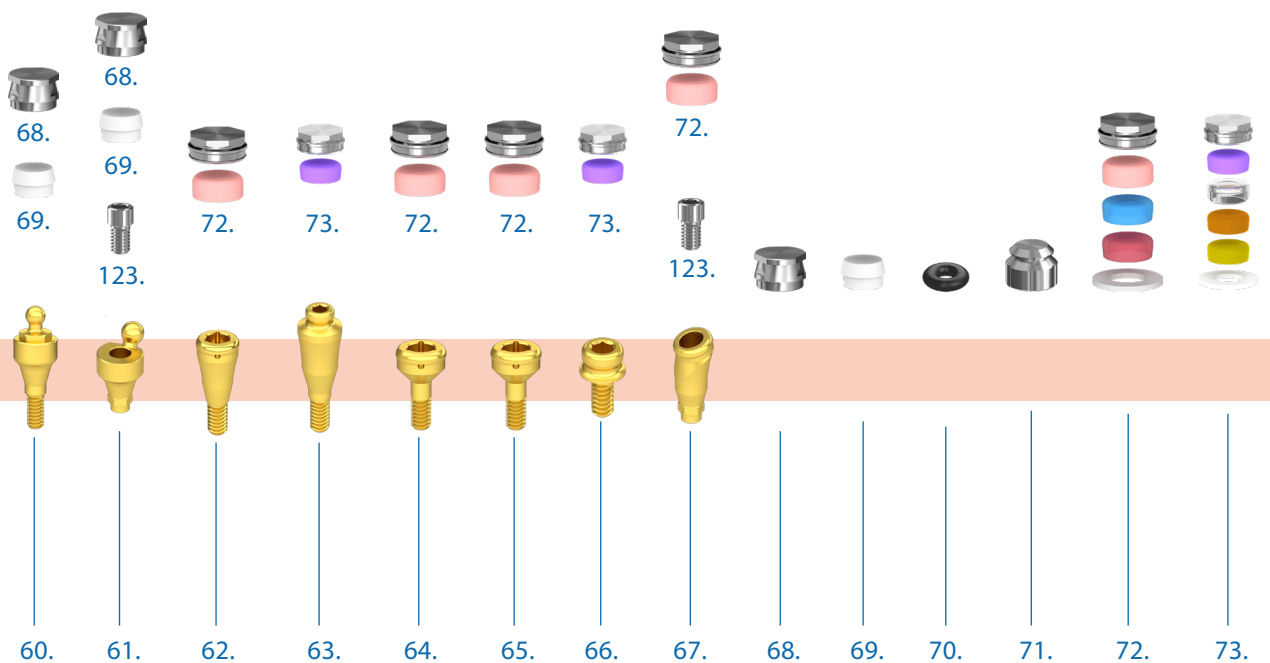

eco-plant abutments

FOR SCREW-RETAINED RESTORATIONS

- 74. Multi-unit abutment, straight, screwable
- 75. Multi-unit abutment, straight, through-bolted
- 76. Multi-unit abutment, angled
- 77. Multi-Compact abutment, cup
- 78. MC - multi-unit cone
- 79. MC - multi-unit cone, SR
- 80. MC - ball abutment cone

- 81. MC - locator abutment cone
- 82. MC - adaptable cone
- 83. Multi-unit SR abutment, straight
- 84. Multi-unit SR abutment, through-bolted
- 85. Multi-unit SR abutment, angled

ELEMENTS OF THE CAD-CAM SYSTEM

- 86. Titanium base, positioned
- 87. Titanium base, non-positioned

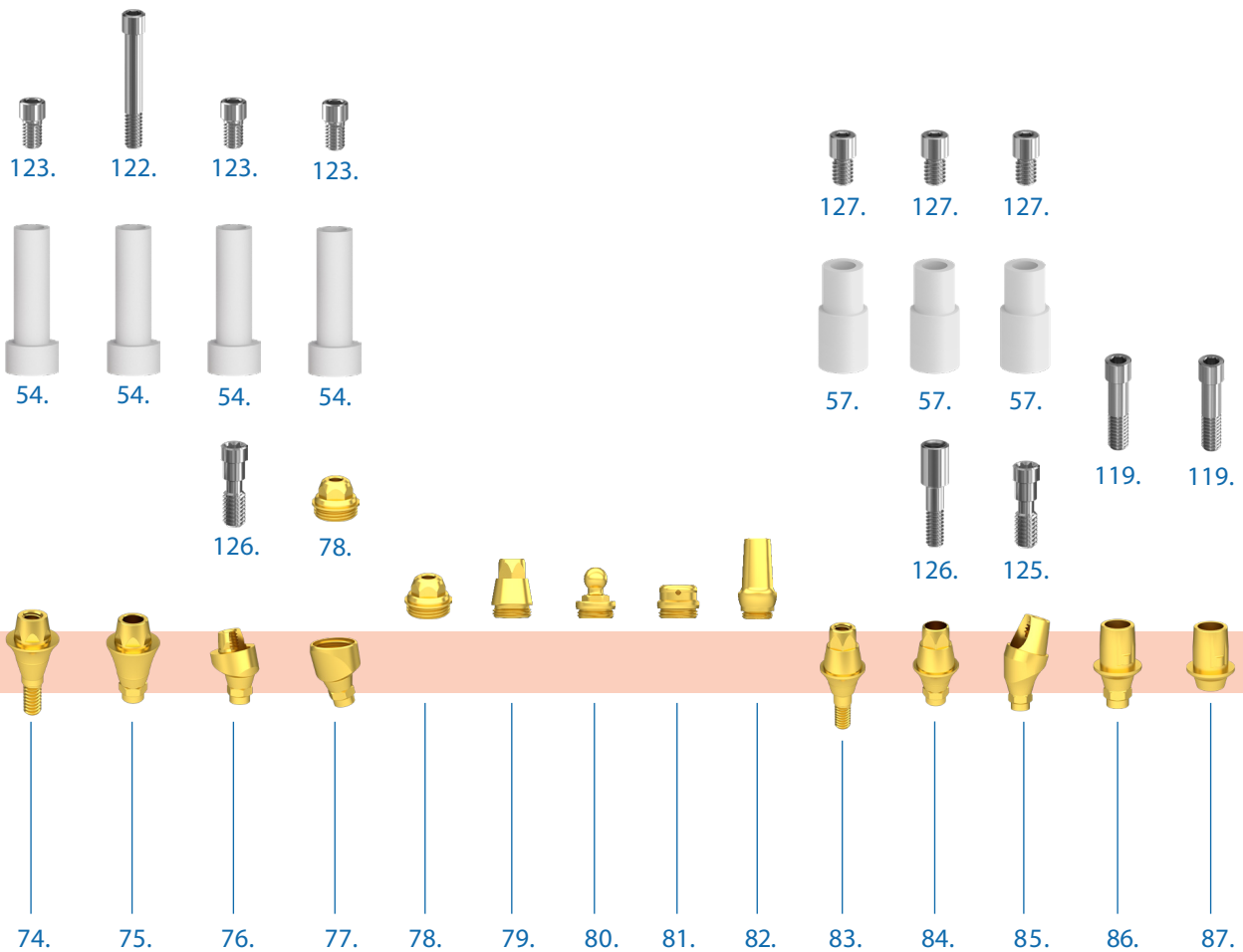

- 88. Titanium base, multi-unit level, positioned
- 89. Titanium base, multi-unit level, non-positioned
- 90. Titanium base, multi-unit level, positioned, SR
- 91. Titanium base, multi-unit level, non-positioned, SR
- 92. Titanium base, angled
- 93. Flexi base
- 94. Zircon abutment, with titanium base
- 95. Zircon abutment, with titanium base, angled
- 96. Tube abutment, positioned
- 97. Tube abutment, non-positioned
- 98. Tube abutment, stepped, positioned
- 99. Tube abutment, stepped, non-positioned
- 100. Scanbody, through-bolted, positioned
- 101. Scanbody, through-bolted, non-positioned

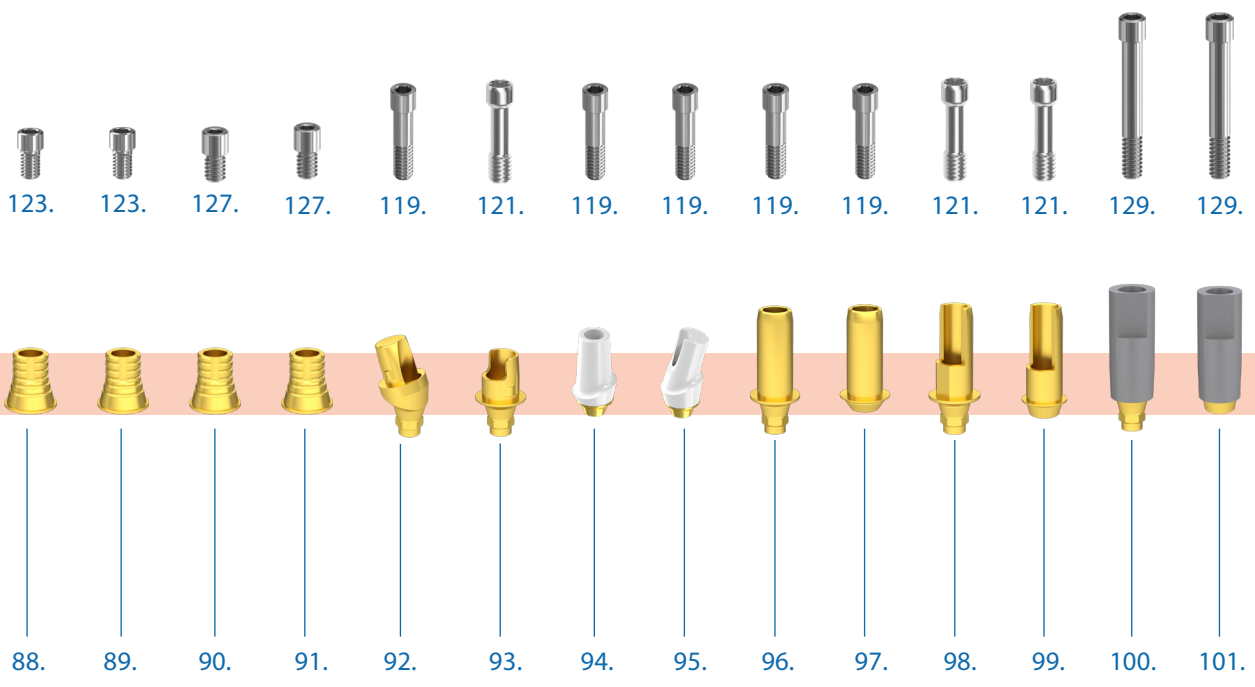

eco-plant abutments

102. Scanbody, through-bolted, multi-unit level, positioned

103. Scanbody, through-bolted, multi-unit level, non-positioned

OTHER ABUTMENTS

104. Spacer, implant level, positioned

105. Spacer, implant level, non-positioned

106. Spacer, multi-unit level, positioned

107. Spacer, multi-unit level, non-positioned

108. Test abutment

109. Test abutment, angled

SCREWS

110. Locking screw

111. Locking screw, for spacer

112. Impression coping screw, for open tray

113. Impression coping screw, for open tray, multi-unit level

114. Impression coping screw, for open tray, multi-unit level, SR

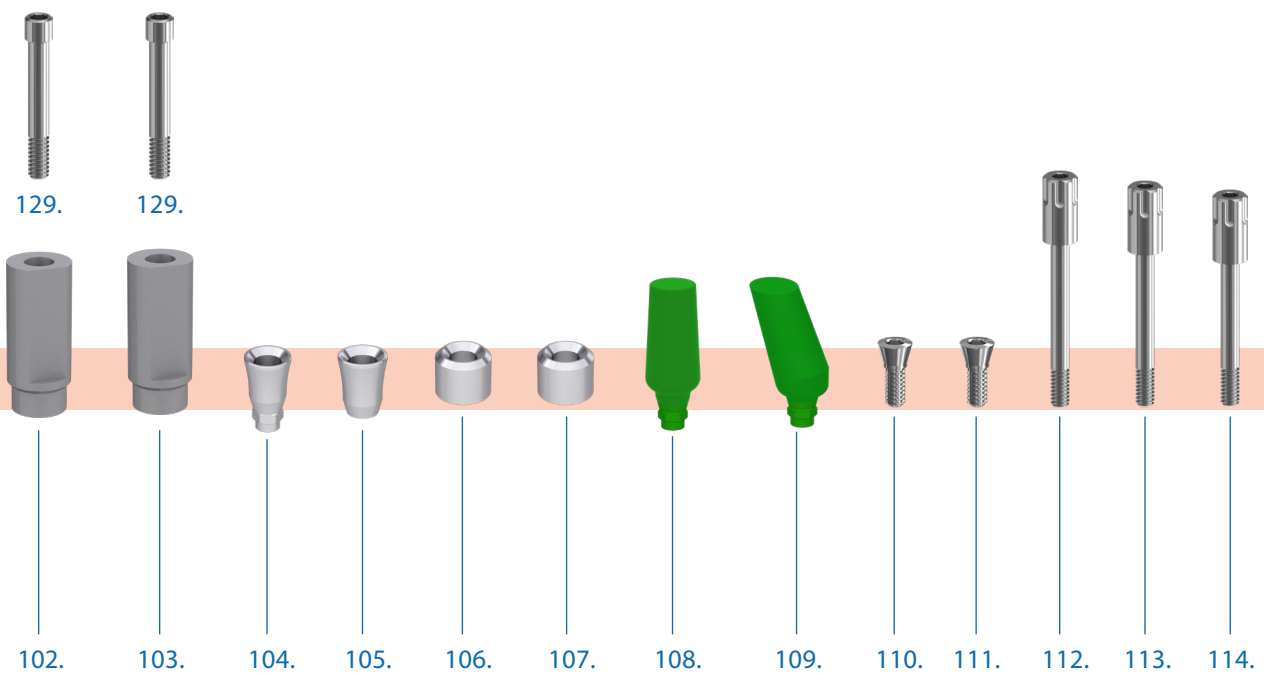

115. Impression coping screw, for closed tray
116. Impression coping screw, for closed tray, multi-unit level
117. Impression coping screw, for closed tray, multi-unit level, SR
118. Impression coping screw, for closed tray, multi-unit level, parallel
119. Surgical abutment screw
120. Surgical abutment screw, technical
121. Surgical abutment screw PCT
122. Multi-unit through-bolt
123. Multi-unit abutment screw
124. Multi-unit abutment screw, PCT
125. Multi-unit abutment screw, for angled abutment
126. Multi-unit through-bolt, SR
127. Multi-unit abutment screw, SR
128. BR interface Multi-unit abutment screw
129. Scanbody through-bolt
130. Lab analog screw
131. Dental retaining screw

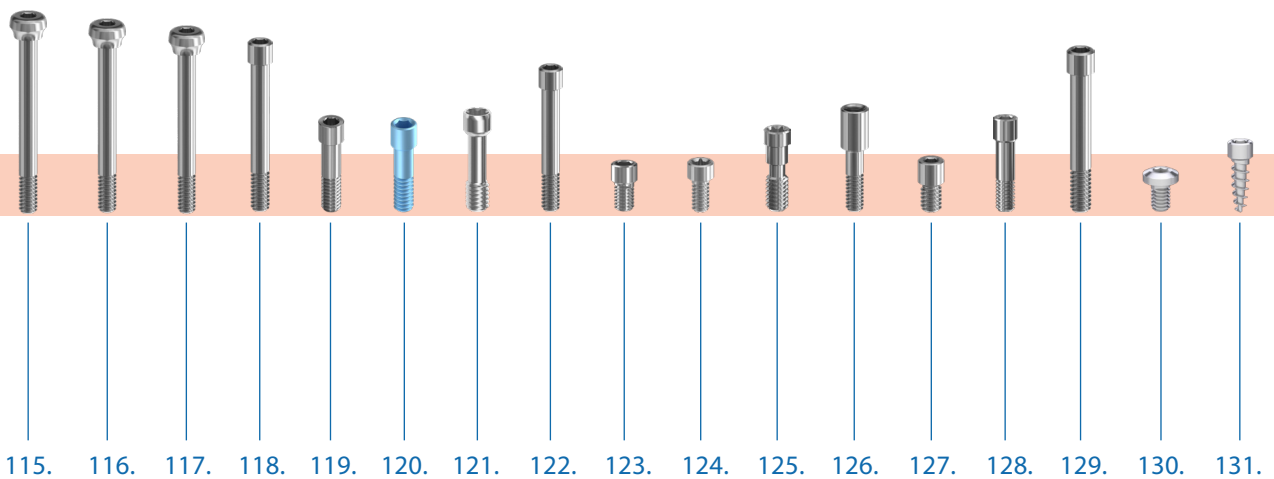

Sizes available of the **eco-plant** abutments

LAB ANALOG

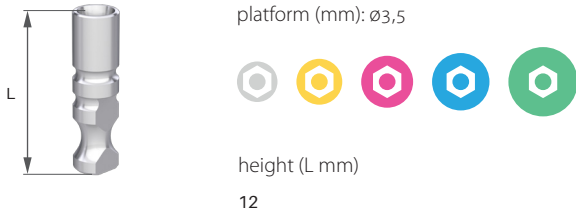

LAB ANALOG, MULTI-UNIT SR

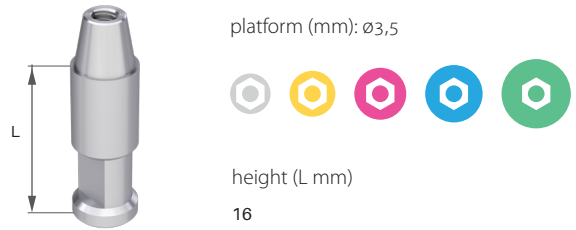

LAB ANALOG, FOR DIGITAL SCAN

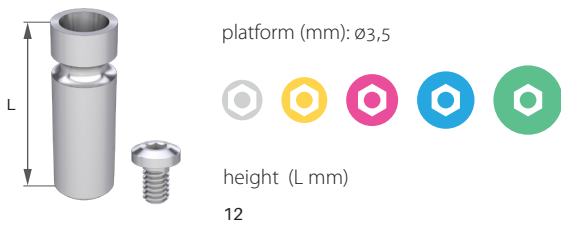

LAB ANALOG, MULTI-UNIT DIGITAL

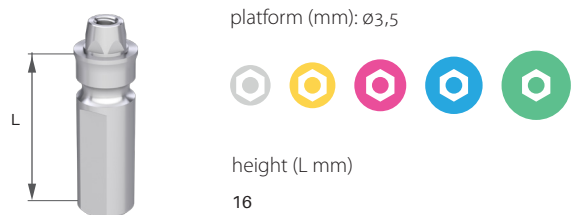

LAB ANALOG, LOCATOR

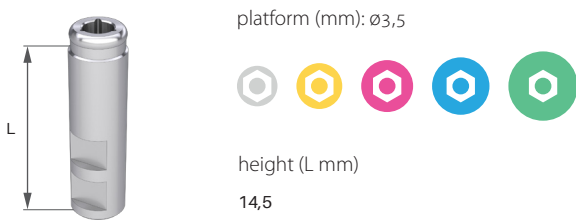

LAB ANALOG, MULTI-UNIT DIGITAL SR

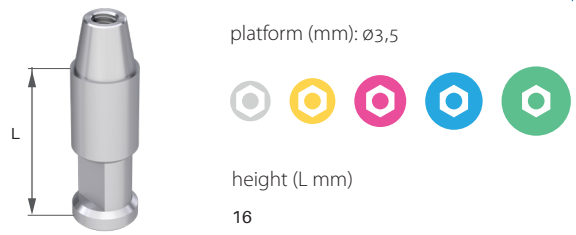

LAB ANALOG, BALL ATTACHMENT

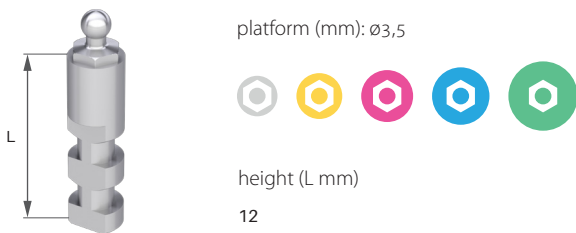

HEALING ABUTMENT, NARROW

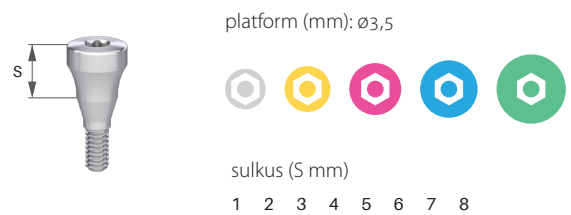

LAB ANALOG, MULTI-UNIT

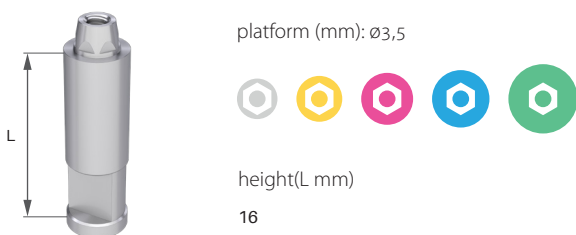

HEALING ABUTMENT, ANATOMICAL

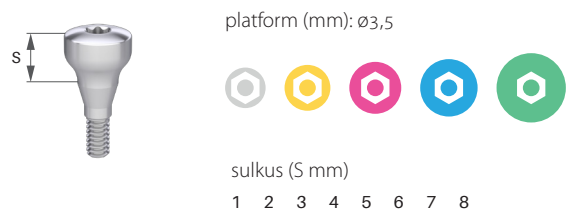

HEALING ABUTMENT, ANATOMICAL, LOCAL

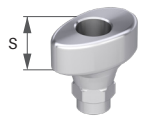

platform (mm): $\varnothing 3,5$



sulkus (S mm)
2 4 6 8

IMPRESSION COPING FOR OPEN TRAY

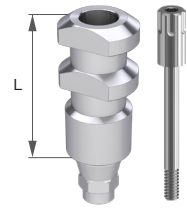

platform (mm): $\varnothing 3,5$



height (L mm)
10 14

HEALING ABUTMENT, CONICAL

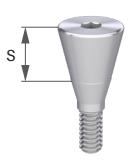

platform (mm): $\varnothing 3,5$



sulkus (S mm)
1 2 3 4 5 6 7 8

IMPRESSION COPING FOR OPEN TRAY, MULTI-UNIT LEVEL, POSITIONED

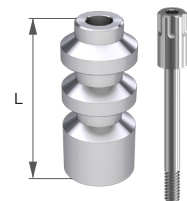

platform (mm): $\varnothing 3,5$



height (L mm)
10

HEALING ABUTMENT, MULTI-UNIT

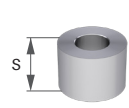

platform (mm): $\varnothing 3,5$



sulkus (S mm)
3 4 5

IMPRESSION COPING FOR OPEN TRAY, MULTI-UNIT LEVEL, NON-POSITIONED

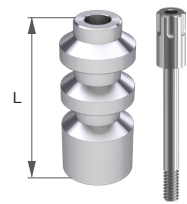

platform (mm): $\varnothing 3,5$



height (L mm)
10

HEALING ABUTMENT, MULTI-UNIT SR

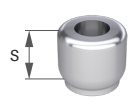

platform (mm): $\varnothing 3,5$



IMPRESSION COPING FOR OPEN TRAY, MULTI-UNIT LEVEL, POSITIONED, SR

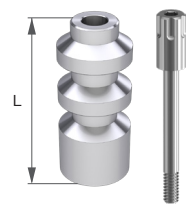

platform (mm): $\varnothing 3,5$



height (L mm)
10

HEALING ABUTMENT, MULTI-UNIT, LOCAL

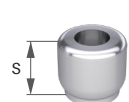

platform (mm): $\varnothing 3,5$



sulkus (S mm)
3 4 5 6

IMPRESSION COPING FOR OPEN TRAY, MULTI-UNIT LEVEL, NON-POSITIONED, SR

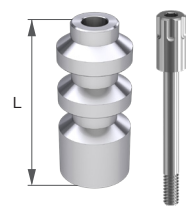

platform (mm): $\varnothing 3,5$



height (L mm)
10

Sizes available of the **eco-plant** abutments

IMPRESSION COPING FOR CLOSED TRAY

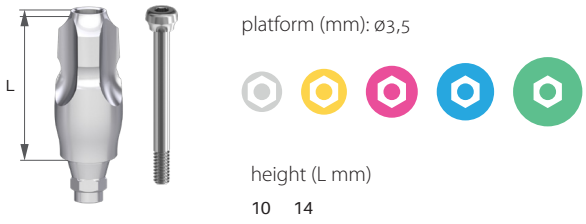

IMPRESSION COPING FOR CLOSED TRAY, PARALLEL

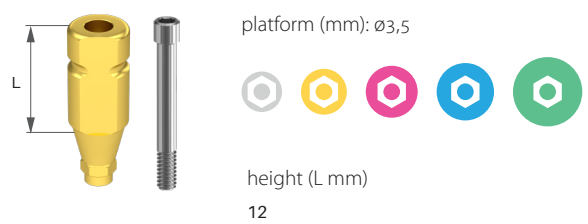

IMPRESSION COPING FOR CLOSED TRAY, MULTI-UNIT LEVEL, POSITIONED

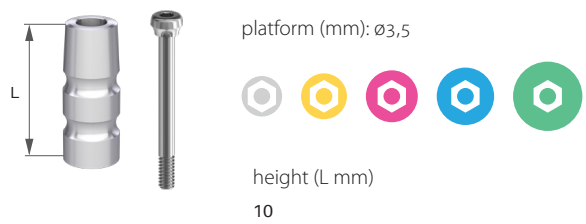

IMPRESSION COPING FOR CLOSED TRAY, ANGLED

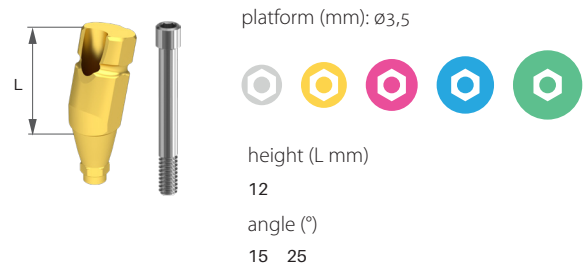

IMPRESSION COPING FOR CLOSED TRAY, MULTI-UNIT LEVEL, NON-POSITIONED

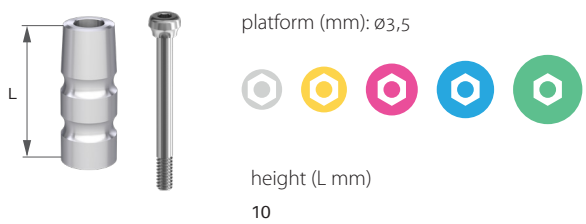

TEMPORARY ABUTMENT, IMPLANT LEVEL, POSITIONED

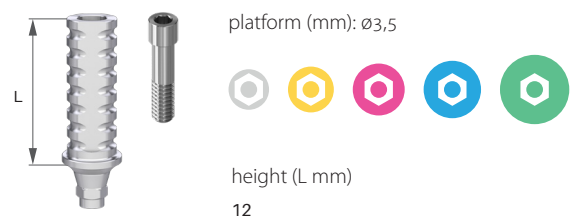

IMPRESSION COPING FOR CLOSED TRAY, MULTI-UNIT LEVEL, POSITIONED, SR

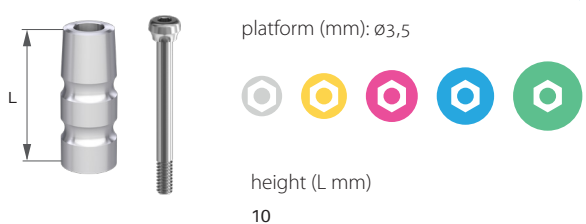

TEMPORARY ABUTMENT, MULTI-UNIT LEVEL, POSITIONED

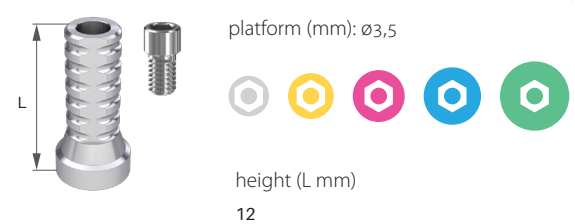

IMPRESSION COPING FOR CLOSED TRAY, MULTI-UNIT LEVEL, NON-POSITIONED, SR

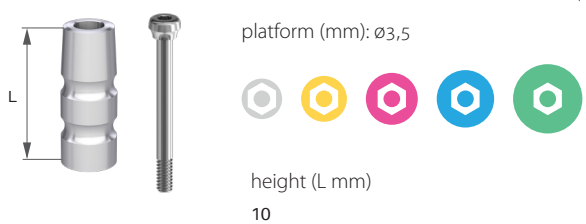

TEMPORARY ABUTMENT, MULTI-UNIT LEVEL, NON-POSITIONED

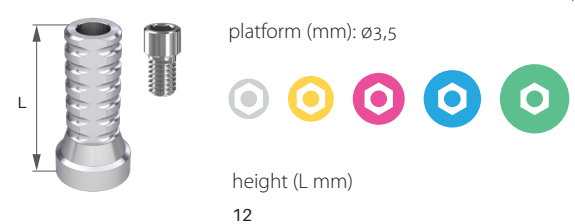

TEMPORARY ABUTMENT, MULTI-UNIT LEVEL, POSITIONED, SR

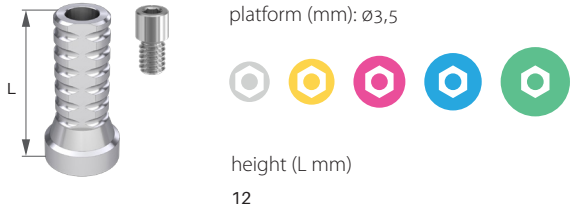

UNIVERSAL ABUTMENT, STRAIGHT, NON-POSITIONED

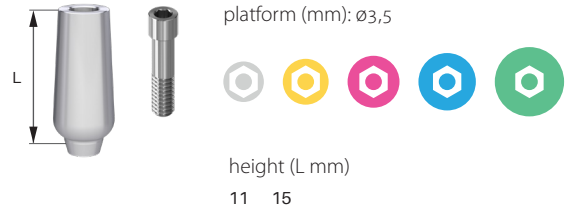

TEMPORARY ABUTMENT, MULTI-UNIT LEVEL, NON-POSITIONED SR

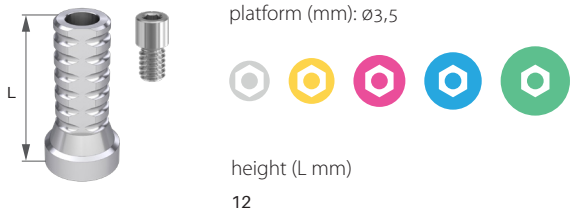

UNIVERSAL ABUTMENT, STRAIGHT MV

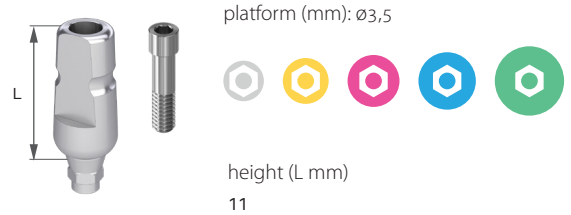

NARROW ABUTMENT, STRAIGHT

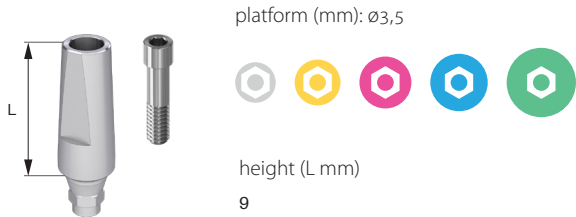

UNIVERSAL ABUTMENT, ANGLED

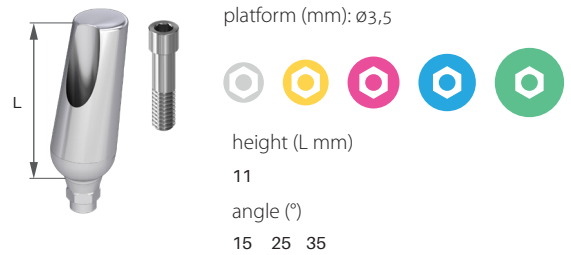

NARROW ABUTMENT, ANGLED

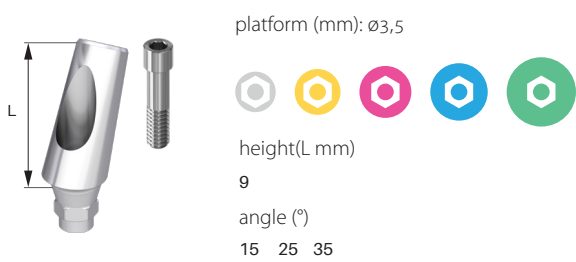

ANATOMICAL ABUTMENT, STRAIGHT

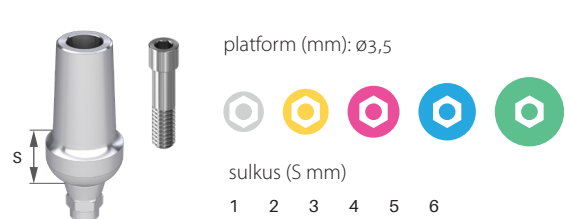

UNIVERSAL ABUTMENT, STRAIGHT, POSITIONED

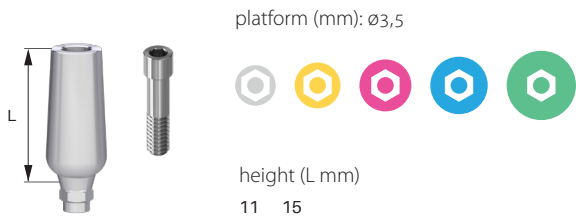

ANATOMICAL ABUTMENT, ANGLED

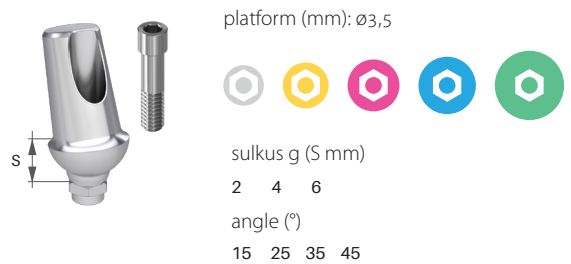

Sizes available of the **eco-plant** abutments

CYLINDRICAL ABUTMENT

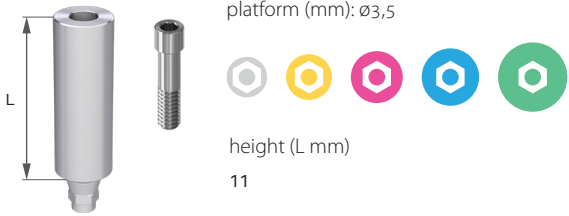

CASTABLE PLASTIC ABUTMENT, FOR BR INTERFACE, POSITIONED

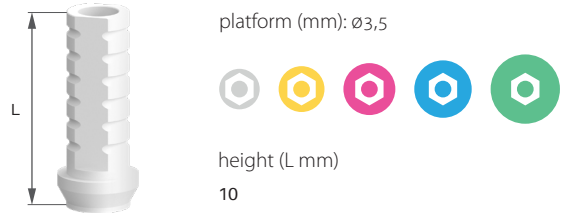

TRAPEZOIDAL ABUTMENT

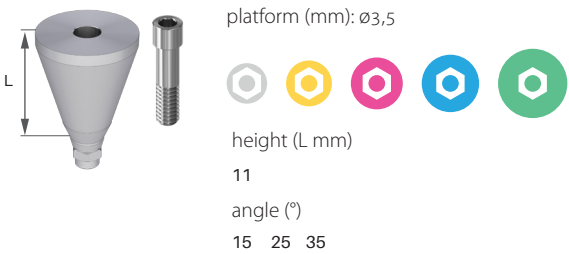

CASTABLE PLASTIC ABUTMENT, FOR BR INTERFACE, NON-POSITIONED

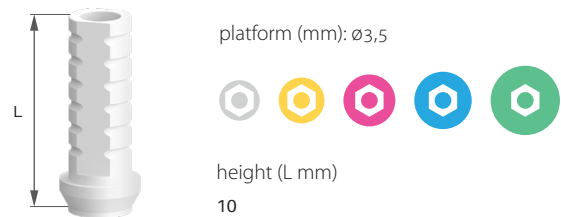

DELTA ABUTMENT

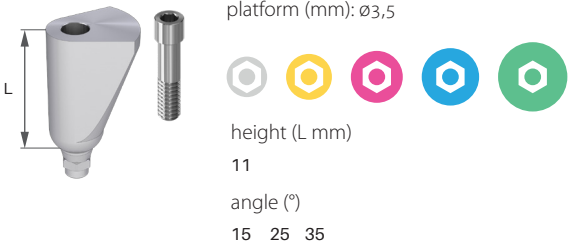

CASTABLE PLASTIC ABUTMENT, FOR TITANIUM BASE

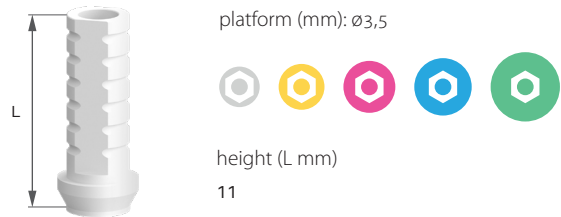

BR INTERFACE

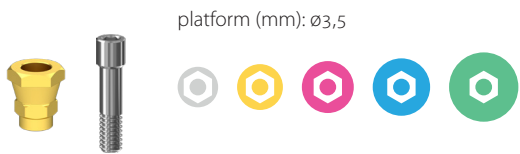

CASTABLE PLASTIC ABUTMENT, FOR MULTI-UNIT LEVEL TITANIUM BASE

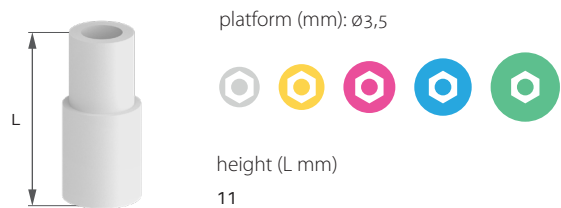

BR INTERFACE, SCREWABLE

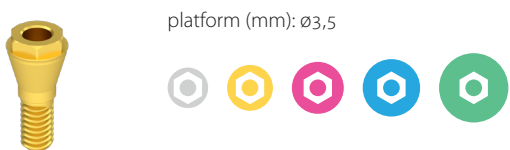

CASTABLE PLASTIC ABUTMENT, ANGLED, FOR MULTI-UNIT LEVEL TITANIUM BASE

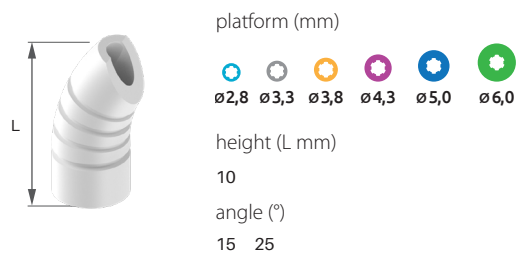

CASTABLE PLASTIC ABUTMENT, FOR MULTI-UNIT LEVEL TITANIUM BASE, SR

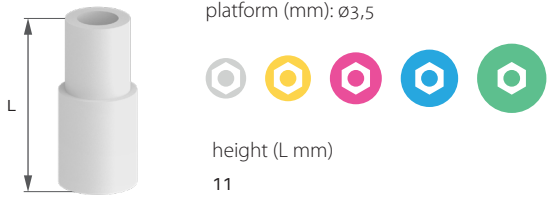

CASTABLE PLASTIC ABUTMENT, MULTI-UNIT LEVEL, POSITIONED, SR

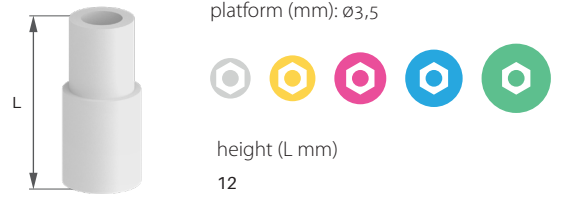

CASTABLE PLASTIC ABUTMENT, ANGLED, FOR MULTI-UNIT LEVEL TITANIUM BASE, SR

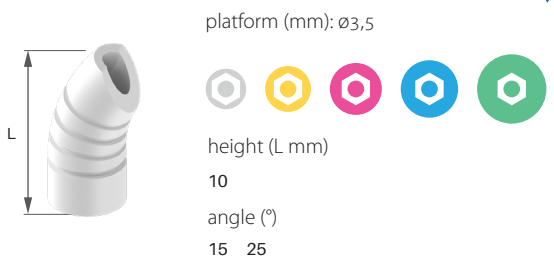

CASTABLE PLASTIC ABUTMENT, MULTI-UNIT LEVEL, NON-POSITIONED, SR

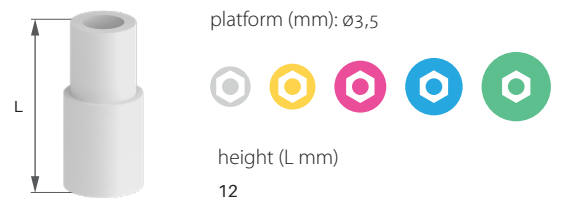

CASTABLE PLASTIC ABUTMENT, MULTI-UNIT LEVEL, POSITIONED

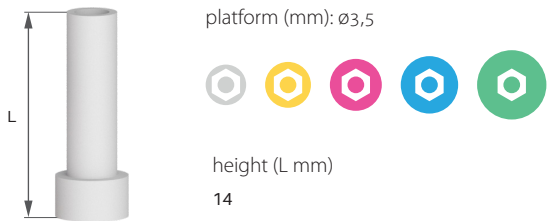

CASTABLE PLASTIC ABUTMENT, ANGLED, MULTI-UNIT LEVEL SR

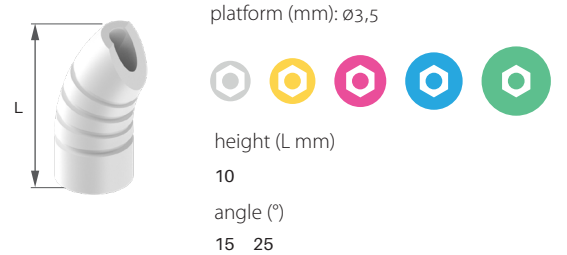

CASTABLE PLASTIC ABUTMENT, MULTI-UNIT LEVEL, NON-POSITIONED

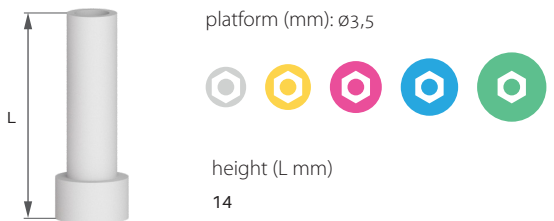

BALL ATTACHMENT ABUTMENT OC

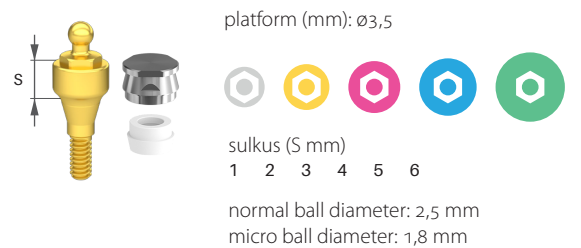

CASTABLE PLASTIC ABUTMENT, ANGLED, MULTI-UNIT LEVEL

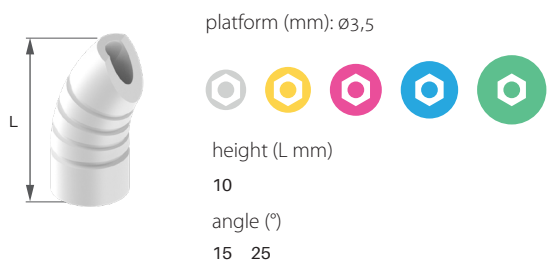

BALL ATTACHMENT ABUTMENT, ANGLED OC

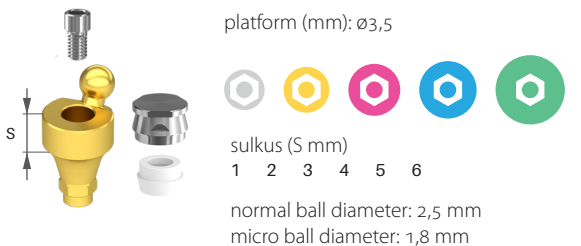

Sizes available of the **eco-plant** abutments

LOCATOR ABUTMENT

platform (mm): $\varnothing 3,5$

sulkus (S mm)
0,5 1 2 3 4 5 6 7 8 9

LOCATOR ABUTMENT, ANGLED

platform (mm): $\varnothing 3,5$

sulkus (S mm)
0,5 2 4 6

angle (°)
15 25

LOCATOR ABUTMENT, MINI

platform (mm): $\varnothing 3,5$

sulkus (S mm)
1 2 3 4 5 6 7

OC CAP, METAL

platform (mm): $\varnothing 3,5$

normal ball diameter: 2,5 mm
micro ball diameter: 1,8 mm

LOCATOR ABUTMENT, MULTI-UNIT LEVEL

platform (mm): $\varnothing 3,5$

sulkus (S mm)
3 4 5

OC INSERT, PLASTIC

platform (mm): $\varnothing 3,5$

normal ball diameter: 2,5 mm
micro ball diameter: 1,8 mm

LOCATOR ABUTMENT, MULTI-UNIT LEVEL SR

platform (mm): $\varnothing 3,5$

sulkus (S mm)
3 4 5

O-RING

platform (mm): $\varnothing 3,5$

LOCATOR ABUTMENT, MINI, MULTI-UNIT LEVEL

platform (mm): $\varnothing 3,5$

sulkus (S mm)
3 4 5

O-RING'S METAL CAP

platform (mm): $\varnothing 3,5$

normal ball diameter: 2,5 mm
micro ball diameter: 1,8 mm

LOCATOR CAP SET

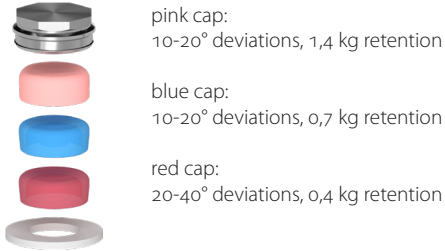

MICROLOCK CAP SET



MULTI-UNIT ABUTMENT, STRAIGHT, SCREWABLE

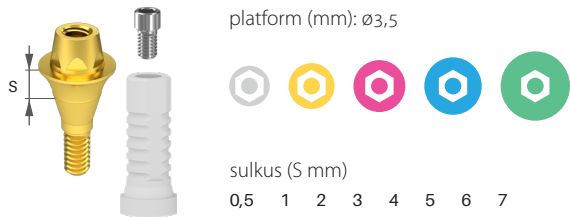

MULTI-UNIT ABUTMENT, STRAIGHT, THROUGH-BOLTED

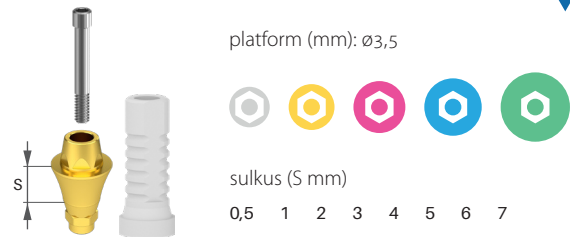

MULTI-UNIT ABUTMENT, ANGLED

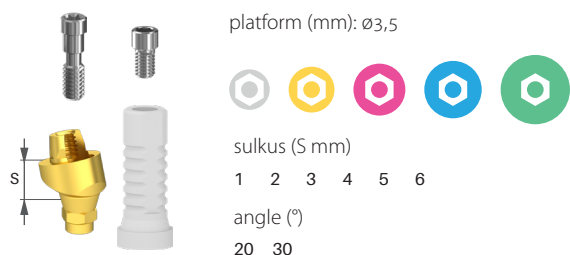

MULTI-COMPACT ABUTMENT, CUP

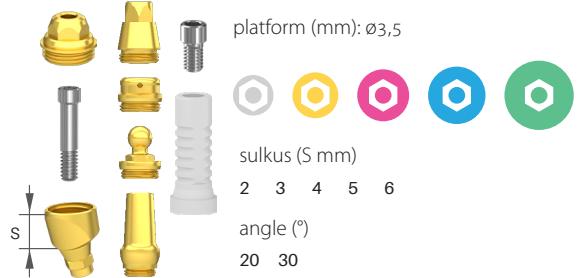

MC - MULTI-UNIT CONE

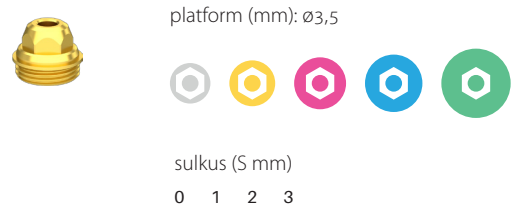

MC - MULTI-UNIT CONE, SR

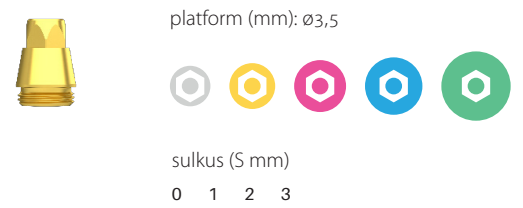

MC - BALL ABUTMENT CONE

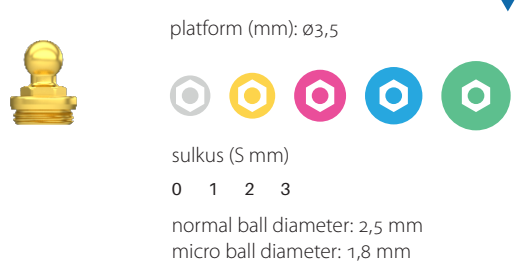

MC - LOCATOR ABUTMENT CONE

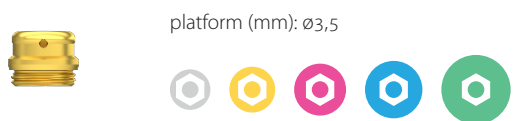

Sizes available of the **eco-plant** abutments

MC - ADAPTABLE CONE



platform (mm): $\varnothing 3,5$



TITANIUM BASE, NON-POSITIONED

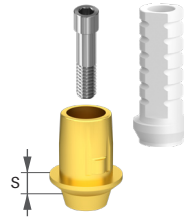

platform (mm): $\varnothing 3,5$



sulkus (S mm)
1 2 3

MULTI-UNIT SR ABUTMENT, STRAIGHT

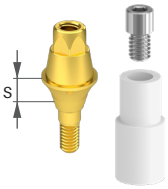

platform (mm): $\varnothing 3,5$



sulkus (S mm)
1 2 3 4 5 6 7

TITANIUM BASE, MULTI-UNIT LEVEL, POSITIONED



platform (mm): $\varnothing 3,5$



MULTI-UNIT SR ABUTMENT, THROUGH-BOLTED

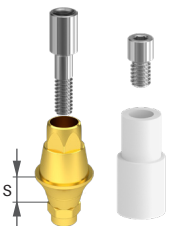

platform (mm): $\varnothing 3,5$



sulkus (S mm)
1 2 3 4 5 6 7

TITANIUM BASE, MULTI-UNIT LEVEL, NON-POSITIONED



platform (mm): $\varnothing 3,5$



MULTI-UNIT SR ABUTMENT, ANGLED

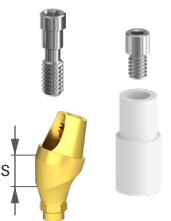

platform (mm): $\varnothing 3,5$



sulkus (S mm)
1 2 3 4 5 6 7
angle (°)
20 30

TITANIUM BASE, MULTI-UNIT LEVEL, POSITIONED, SR



platform (mm): $\varnothing 3,5$



TITANIUM BASE, POSITIONED

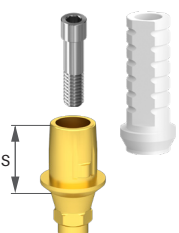

platform (mm): $\varnothing 3,5$



sulkus (S mm)
1 2 3

TITANIUM BASE, MULTI-UNIT LEVEL, NON-POSITIONED, SR

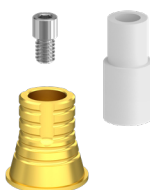

platform (mm): $\varnothing 3,5$



TITANIUM BASE, ANGLED

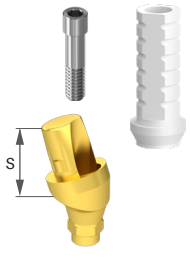

platform (mm): $\varnothing 3,5$



sulkus (S mm)
1 2 3

angle (°)
20 30

TUBE ABUTMENT, NON-POSITIONED

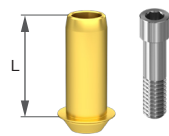

platform (mm): $\varnothing 3,5$



height (L mm)
9

FLEXI BASE

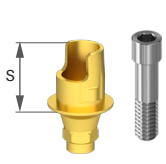

platform (mm): $\varnothing 3,5$



sulkus (S mm)
1 2 3

TUBE ABUTMENT, STEPPED, POSITIONED

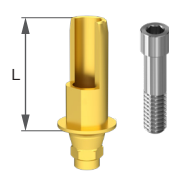

platform (mm): $\varnothing 3,5$



height (L mm)
9

ZIRCON ABUTMENT, WITH TITANIUM BASE

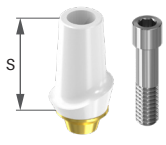

platform (mm): $\varnothing 3,5$



sulkus (S mm)
1 2 3 4 5

TUBE ABUTMENT, STEPPED, NON-POSITIONED

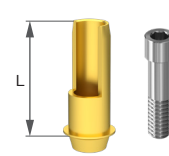

platform (mm): $\varnothing 3,5$



height (L mm)
9

ZIRCON ABUTMENT, WITH TITANIUM BASE, ANGLED

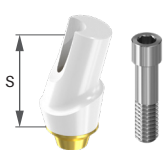

platform (mm): $\varnothing 3,5$



sulkus (S mm)
1 2 3 4 5

angle (°)
15 25

SCANBODY, THROUGH-BOLTED, POSITIONED

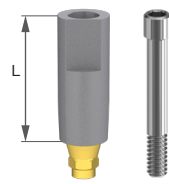

platform (mm): $\varnothing 3,5$



height (L mm)
10

TUBE ABUTMENT, POSITIONED

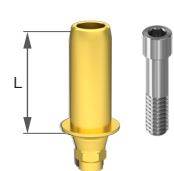

platform (mm): $\varnothing 3,5$



height (L mm)
9

SCANBODY, THROUGH-BOLTED, NON-POSITIONED

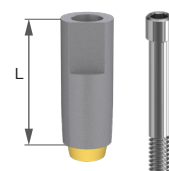

platform (mm): $\varnothing 3,5$



height (L mm)
10

Sizes available of the **eco-plant** abutments

SCANBODY, THROUGH-BOLTED, MULTI-UNIT LEVEL, POSITIONED

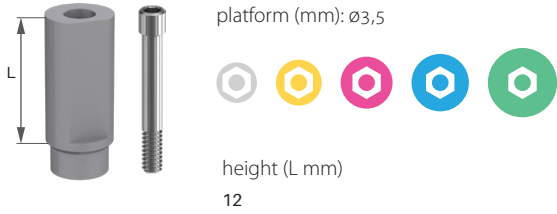

SPACER, MULTI-UNIT LEVEL, POSITIONED

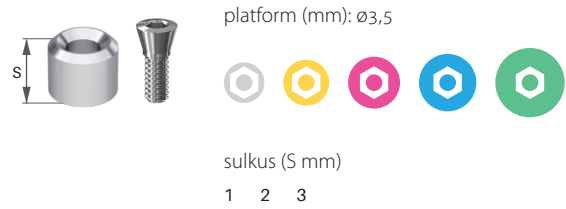

SCANBODY, THROUGH-BOLTED, MULTI-UNIT LEVEL, NON-POSITIONED

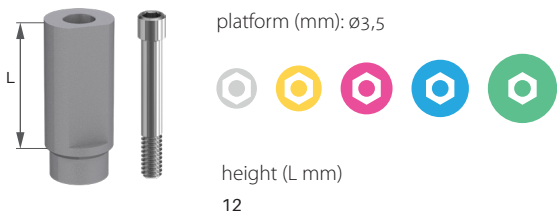

SPACER, MULTI-UNIT LEVEL, NON-POSITIONED

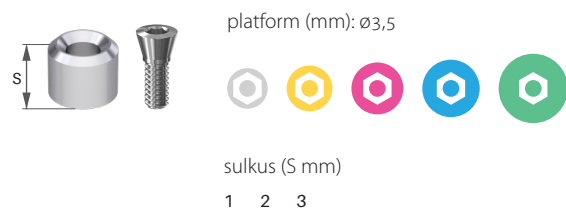

SPACER, IMPLANT LEVEL, POSITIONED

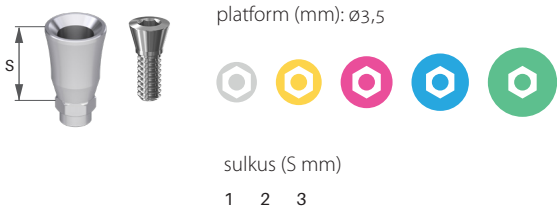

TEST ABUTMENT

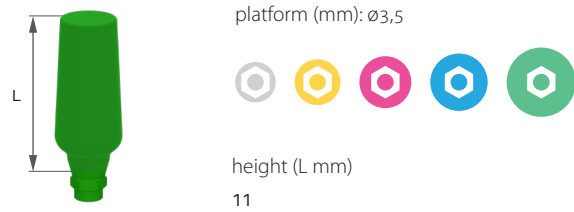

SPACER, IMPLANT LEVEL, NON-POSITIONED

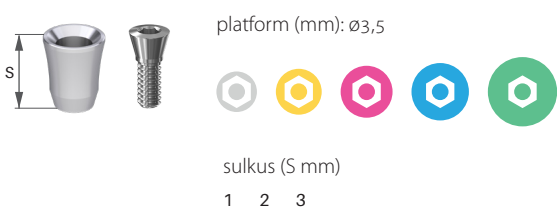

TEST ABUTMENT, ANGLED

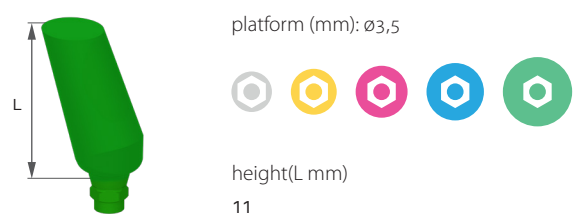

Sizes available of the **eco-plant** screws

LOCKING SCREW



platform (mm): $\varnothing 3,5$



IMPRESSION COPING SCREW, FOR CLOSED TRAY, MULTI-UNIT LEVEL



platform (mm): $\varnothing 3,5$



LOCKING SCREW, FOR SPACER



platform (mm): $\varnothing 3,5$



IMPRESSION COPING SCREW, FOR CLOSED TRAY, MULTI-UNIT LEVEL, PARALLEL



platform (mm): $\varnothing 3,5$



IMPRESSION COPING SCREW, FOR OPEN TRAY



platform (mm): $\varnothing 3,5$



SURGICAL ABUTMENT SCREW



platform (mm): $\varnothing 3,5$



IMPRESSION COPING SCREW, FOR OPEN TRAY, MULTI-UNIT LEVEL



platform (mm): $\varnothing 3,5$



SURGICAL ABUTMENT SCREW, TECHNICAL



platform (mm): $\varnothing 3,5$



IMPRESSION COPING SCREW, FOR CLOSED TRAY



platform (mm): $\varnothing 3,5$



SURGICAL ABUTMENT SCREW PCT



platform (mm): $\varnothing 3,5$



MULTI-UNIT THROUGH-BOLT



platform (mm): $\varnothing 3,5$



MULTI-UNIT ABUTMENT SCREW, SR



platform (mm): $\varnothing 3,5$



MULTI-UNIT ABUTMENT SCREW



platform (mm): $\varnothing 3,5$



BR INTERFACE ABUTMENT SCREW



platform (mm): $\varnothing 3,5$



MULTI-UNIT ABUTMENT SCREW, PCT



platform (mm): $\varnothing 3,5$



SCANBODY THROUGH-BOLT



platform (mm): $\varnothing 3,5$



MULTI-UNIT ABUTMENT SCREW, FOR ANGLED ABUTMENT



platform (mm): $\varnothing 3,5$



LAB ANALOG SCREW



platform (mm): $\varnothing 3,5$



MULTI-UNIT THROUGH-BOLT, SR



platform (mm): $\varnothing 3,5$



DENTAL RETAINING SCREW



platform (mm): $\varnothing 3,5$



eco
plant
SURGICAL INSTRUMENTS



INSTRUMENTS | TABLE OF CONTENTS

Large Instrument Kit	50
Small Instrument Kit	52
Surgical drills	54
Ratchet torque wrench	55



eco-plant large instrument kit

Our set of instruments includes instruments essential for dental implantation. The Eco-plant Large Instrument Kit contains 33 instruments, in a wide range of sizes, for a wide range of applications. The trays are structured

according to the surgical order, labeling makes their usage easier. The tray is also suitable for sterilizing the instruments, this can be done together with the box or separately, as the tray can be uplifted from the box.

The layout of the Eco-plant Large Instrument Kit elements

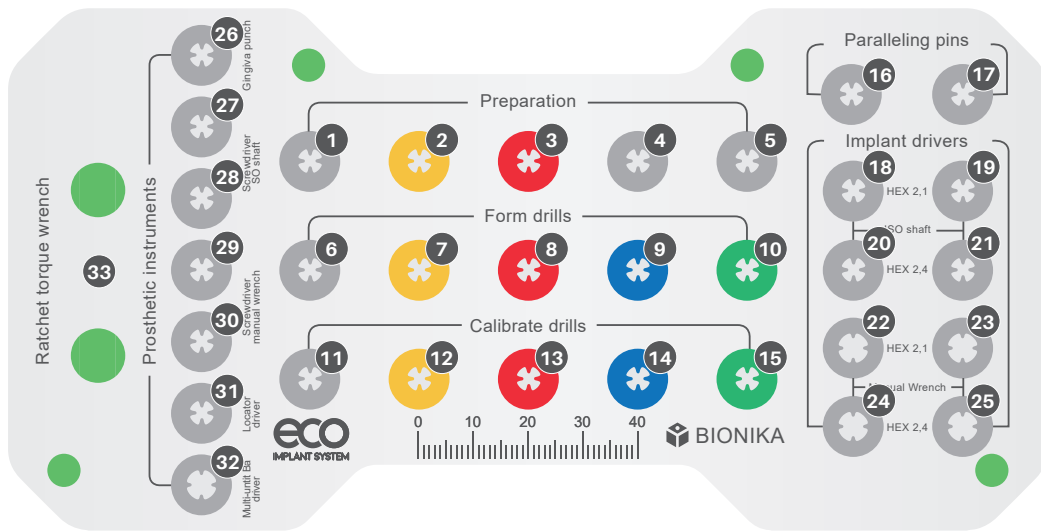

Preparation

- 1. Spear-pointed drill
- 2. Pre-drill Ø2.0
- 3. Pre-drill Ø2.5
- 4. Pre-drill Ø 2.7
- 5. Depth gauge

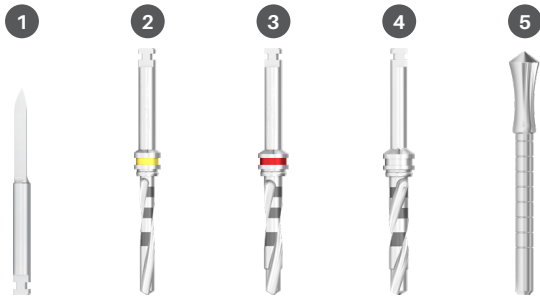

Thread formation

- 6. Core drill, Ø 2.8
- 7. Core drill, Ø 3.2
- 8. Core drill, Ø 3.7
- 9. Core drill, Ø 4.2
- 10. Core drill, Ø 4.7



Thread calibration

- 11. Thread calibrator drill Ø 3.2
- 12. Thread calibrator drill Ø 3.7
- 13. Thread calibrator drill Ø 4.2
- 14. Thread calibrator drill Ø 4.7
- 15. Thread calibrator drill Ø 5.5

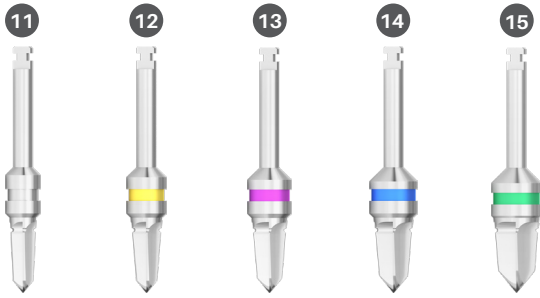

Paralleling pins

- 16. Paralleling pin, slim
- 17. Paralleling pin, thick

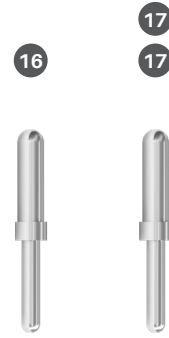

Implant drivers, mechanical

- 18. 6LT 2,1 x L6
- 19. 6LT 2,1 x L12
- 20. 6LT 2,4 x L6
- 21. 6LT 2,4 x L12

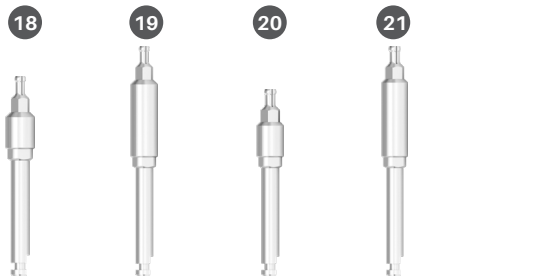

Implant drivers, manual

- 22. 6LT 2,1 x L6
- 23. 6LT 2,1 x L12
- 24. 6LT 2,4 x L6
- 25. 6LT 2,4 x L12

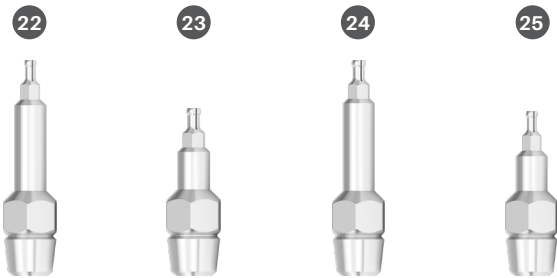

Prosthetic tools

- 26. Gingiva punch Ø4,0xL15
- 27. Head wrench, mechanical 6Lt1,27xL10
- 28. Head wrench, mechanical 6Lt1,27xL15
- 29. Head wrench, manual 6Lt1,27xL10
- 30. Head wrench, manual 6Lt1,27xL15
- 31. Locator key
- 32. Multi-unit/ball-joint key 6LT2,7

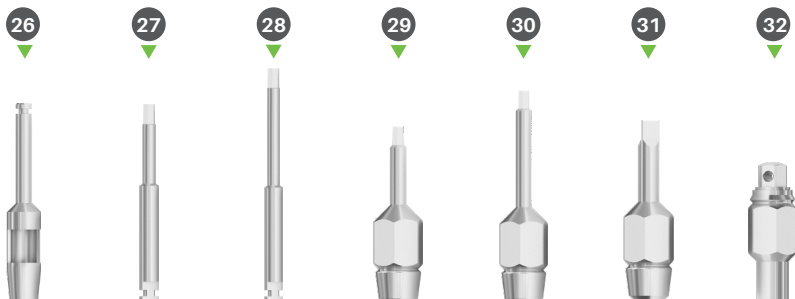

Ratchet torque wrench

- 33. Ratchet torque wrench



eco-plant small instrument kit

The Eco-plant Small Instrument Kit is a practical, more economical solution. The instruments that are inevitable for surgeries can be found in the small tray as they can be found in the large tray as well, only in a smaller range of sizes. There are 19 instruments in the small instrument tray.

The layout of the elements of the **Eco-plant Small instrument kit**

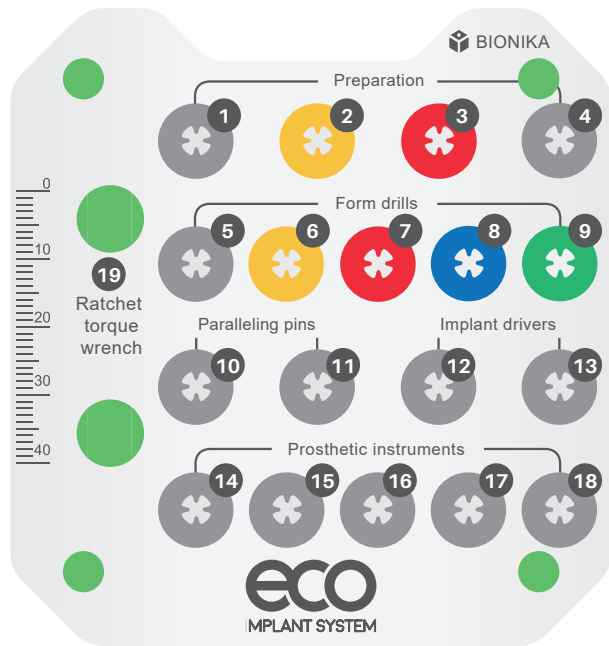

Preparation

- 1. Spear-pointed drill
- 2. Pre-drill Ø2.0
- 3. Pre-drill Ø2.5
- 4. Depth gauge

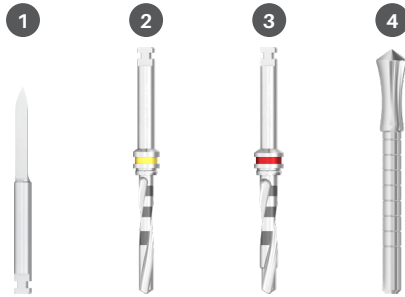

Thread formation

- 5. Core drill, Ø 2.8
- 6. Core drill, Ø 3.2
- 7. Core drill, Ø 3.7
- 8. Core drill, Ø 4.2
- 9. Core drill, Ø 4.7

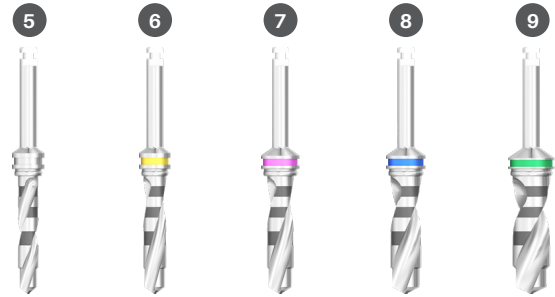

Paralleling pins

- 10. Paralleling pin, slim
- 11. Paralleling pin, thick

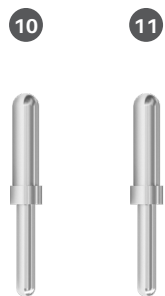

Implant drivers

- 12. Mechanical, 6LT 2,4 x L12
- 13. Manual, 6LT 2,4 x L12

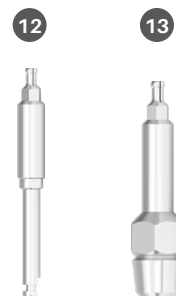

Prosthetic tools

- 14. Gingiva punch Ø4,0xL15
- 15. Head wrench, mechanical 6Lt1,27xL10
- 16. Head wrench, manual 6Lt1,27xL10
- 17. Locator key
- 18. Multi-unit/ball-head key 6LT2,7

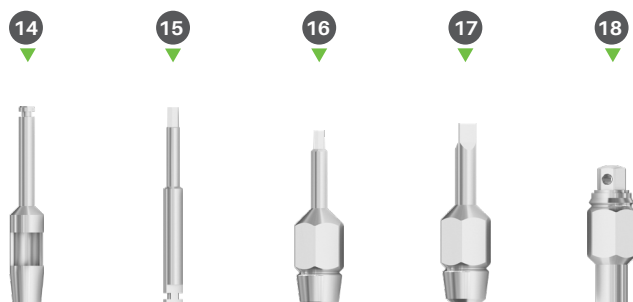

Ratchet torque wrench

- 19. Ratchet torque wrench



eco-plant surgical drills

The **BIONIKA drills** - which can be used during implant insertion - are available in a wide range of sizes (compatible with different instrument kits to provide you with the most economical solution).

Our drills are externally cooled and have bone collecting properties. Acidic alloy steel and excellent sharpness guarantee long-term use. Each drill is provided with the required drilling depths. Diameters are indicated by color codes.

Spiral drills are suitable for preparing implant nests. They are recommended to use according to

the drilling protocol, in the case softer and harder bone structures.

The Thread Calibrator Drills are suitable for expanding the implant nests as needed, so that we can extend the upper third of the bone nest. They are recommended to use in the case of harder than average bone structure.



- 16 mm
- 14,5 mm
- 13 mm
- 11,5 mm
- 10 mm
- 8 mm
- 6 mm

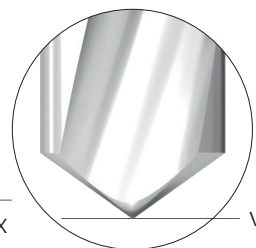

vertex vertex 0 mm

Pre-drills

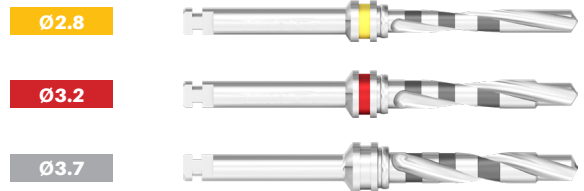

Core drills

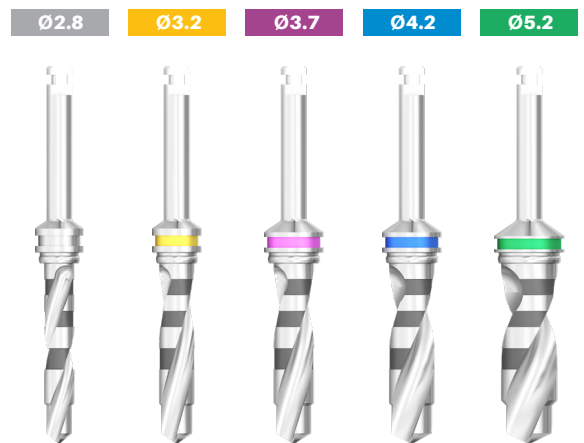

Thread groove calibrating drills

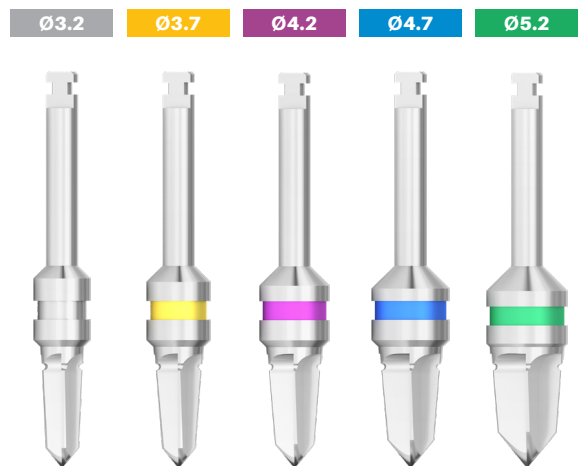

Ratchet torque wrench

The ratchet torque wrench is used to tighten and insert screws and implants. Using pre-set torque, this prevents the implant from fracturing and ensures the optimum power transfer when inserting the implant.

The scale of the torque rates from 15 to 35 Ncm. The

desired torques can be adjusted from 15 Ncm to the right for the desired scale. When the ratchet torque wrench adjuster screw bolted to the stop, the wrench of the torque can be infinite, so it can also be used to produce a much greater torque than the torque shown on the scale, as needed.

- ERGONOMIC CONSTRUCTION • STAINLESS STEEL • RELIABLE LIFETIME • REPLACABLE KEY INTERLINE • PRE-CISE TORQUE CONTROL • SOUND SIGNAL • PROFESSIONAL QUALITY • STABLE TORQUE SCALE DURING USE

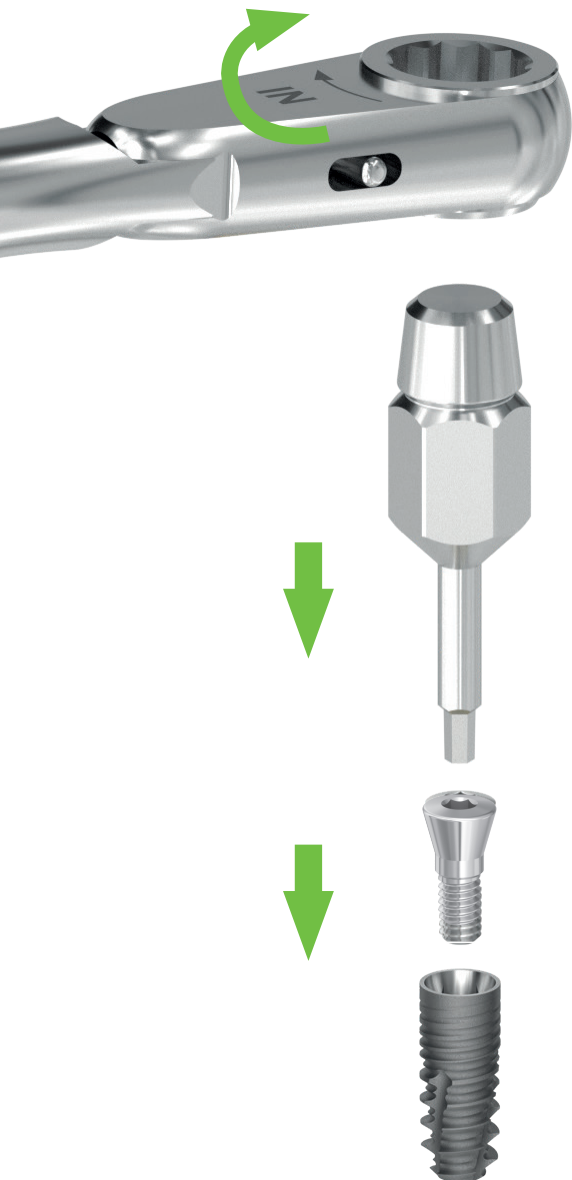

Heads and Screws	Key interline	Torque	
Locking screw		Manual implant driver 10-15 Ncm	
Healing cap			
Sampling head screw for closed and open spoon			
Sampling head for closed and open spoon			
Head screw		Ratchet torque wrench Torque of the required screw tightening: In the case of M1,4 screw it is 15 Ncm In the case of M1,6 screw it is 20 Ncm In the case of M1,8 screw it is 25 Ncm In the case of M2,0 screw it is 30 Ncm	
Universal head, straight			
Universal head, oblique			
Anatomical head, straight			
Anatomical head, oblique			
Titanium base			
Multi-unit head, through-bolted			
Multi-unit head screw, SR head screw			
Multi-unit head, screwable			
SR head, screwable			
Ball head			
Locator head			

The desired torques can be adjusted from 15 Ncm to the right.

15 Ncm 25 Ncm 35 Ncm endless torque





Get to know our other products!

Ask for our catalogs or visit one of our websites below:



www.bionika.hu



www.shop.bionika.hu



